

'24



New Generation  
Kitchen Experience

**SILVERLINE**

Silverline was founded in 1994 to serve in the built-in appliances sector. It offers enjoyable cooking experience for millions of kitchens in more than 70 countries with the mission “transforming kitchens into attractive living spaces with innovative designs and environmentally friendly solutions.”

Silverline focuses on innovation, technology and design, and is one of the largest hood manufacturer in the world. The company has a production capacity of 2.3 million units at its facilities, where it has integrated the new-generation production technologies. Offering innovative products, Silverline has so far received more than 160 international awards, including the most prestigious awards in the world such as the Good Design, Red-Dot, Plus X Award, IF Design, and German Design Award.

Silverline carefully assesses the impacts of its activities and products on the environment and all of its shareholders, and aims to create sustainable value for a better life and a better world.



# CONTENTS

<b>HOODS</b>	8
Technologies	10
Worktop Hoods	20
Suspended Hoods	34
Island Hoods	44
Ceiling Hoods	50
Wall-Mounted Hoods	56
Built-In Hoods	76
Accessories	88
Retro Series	94
Vintage Series	102
<b>OVENS</b>	106
Multifunction Electric Ovens	114
Gas Ovens	130
Free Standing Cookers	132
<b>MICROWAVES</b>	134
<b>HOBS</b>	140
Induction Hobs	144
Vitro Ceramic Hobs	147
Myflame Hobs	148
Glass Built-in Hobs	154
Stainless Steel Hobs	176
Freestanding Hobs	178
<b>REFRIGERATORS</b>	180
Freezers	197
<b>DISHWASHERS</b>	200
<b>WASHING MACHINES</b>	206



## new generation kitchen experience

The dynamics of the age we are living in are our guide. Demand, likes, trends. Our corporate culture is based on the know-how and experience we have accumulated throughout our history. All these values constitute the commitment we represent. Contemporary, far-from-obsolete, innovative products employing the latest technologies and improving quality of life.

# our design approach

The kitchens in our living spaces have had different meanings throughout ages. Today, the kitchen is more than just a cooking area in our homes. New urban lifestyles, such as high technology, common area use and high efficiency, have changed the characteristics of kitchens, making them more integrated into our daily lives. Therefore, Silverline offers an approach that focuses on the changes in the meaning and characteristics of the kitchen while creating new design solutions.

Based on sectoral trends in our designs in the cooking appliances line, we looked for new ways that are meaningful and fascinating for the end user, that emphasize the strong stance of the brand in the built-in appliances industry, that are user-centered and are simplified for the user.





# HOODS

High performance is achieved through smart technologies and strong design. As we spend a great deal of our time there, who doesn't want a clean and aesthetic kitchen?

# TECHNOLOGIES

## SilverConnect

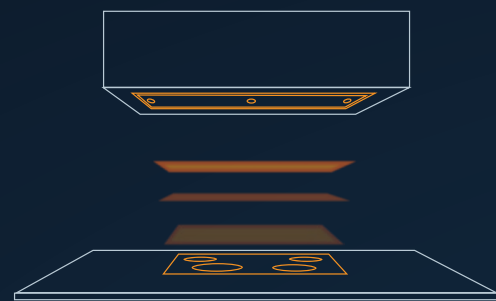

### Bringing intelligence to your kitchen and joy to your life!

Let your cooking and ventilating systems work in harmony, you just enjoy your kitchen.

Connecting the hood with the hob, SilverConnect ensures that ventilation is enabled the minute the cooking process starts. Adjusting the level of ventilation according to the cooking temperature, this technology brings ease of use and innovation to the kitchen.

## SilverWire

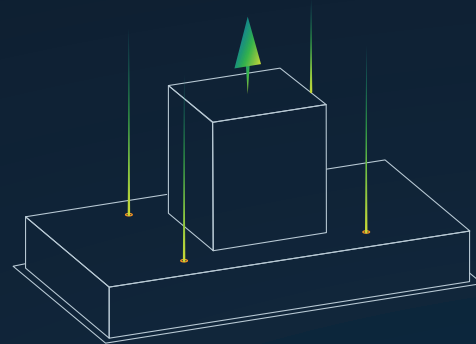

### Easy installation

SilverWire, the steel hanging system that permits easy installation of hoods, offers ease of installation and saves you time.

The hood is easily positioned with the help of 4 steel wires and can be installed by one person only.

## SilverAIS



### Fresh air in your kitchen

Thanks to the AIS technology, the air in your kitchen is under control. When the hood opens, the external valve opens automatically thanks to the RS system to ensure clean air circulation inside. All you need to do is integrate the AIS system in your kitchen hood to make sure that the air in your kitchen is always clean.

## SilverCVS Central Ventilation System

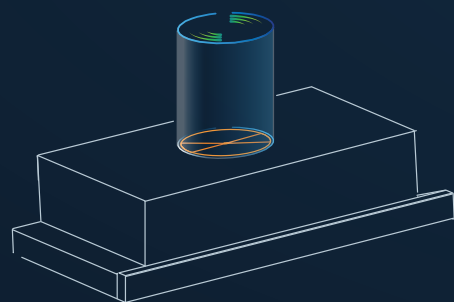

### Maximum technology and energy efficiency!

Developed by Silverline R&D Center, the SilverCVS (Central Ventilation System) technology is integrated into the central airflow stations of the building to optimise energy efficiency.

Having the ability to clean the ambient air without running the hood motor, this system comes to the fore with a low noise level (26 dB) and the self-cleaning function.

## SilverFlex

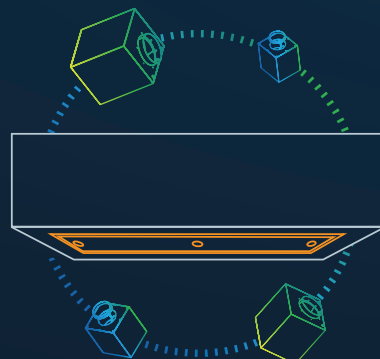

### The silence that your kitchen needs...

Allowing the hood motor to be moved outside in a modular way, the SilverFlex technology offers the user a convenient kitchen experience.

Ensuring that the ventilation motor, the primary source of noise of hoods can be installed outside, this special technology is the beginning of a new silent era in the kitchen.

## SilverSwitch

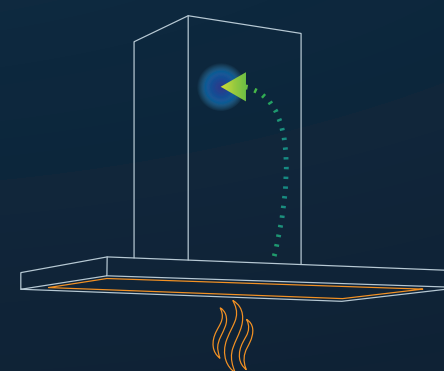

### The flexible circulating air / Exhaust air circuit

Silver Switch Deluxe makes planning exhaust air in summer particularly easy, since no more between the installation of a recirculation or exhaust air system must become. Because Silver Switch Deluxe can do both. At will between recirculation and exhaust air operation be switched, what a high flexibility in the kitchen climate. Silver Switch converts to many ducted Wall and island hoods from Install and retrofit Silverline, provided this with an exhaust duct operate.

## we manage extraction in many ways

Silverline hoods provide you with a fume-free and fresh kitchen thanks to their unique design and different extraction systems for all types of kitchens.



You can cook in peace in your kitchen with the noise level reduced down to 34 dB thanks to this feature.

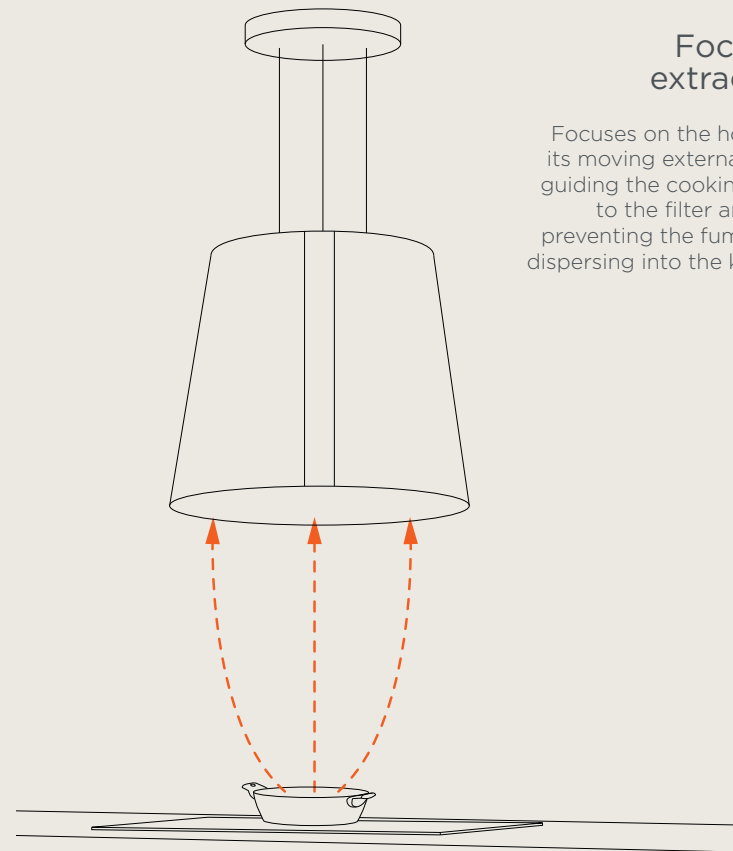

### Focused extraction

Focuses on the hob with its moving external body, guiding the cooking fume to the filter and thus preventing the fume from dispersing into the kitchen.

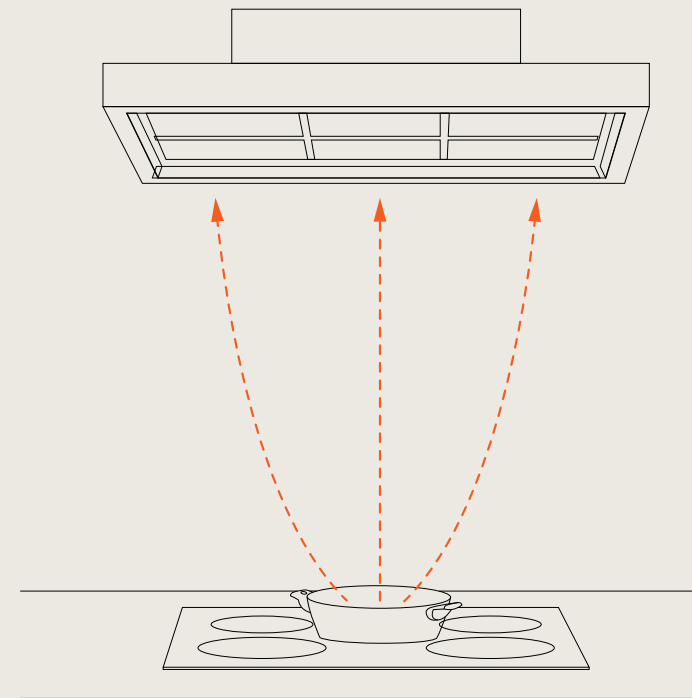

### Ceiling Extraction

Effectively removes cooking fumes and unpleasant odors from kitchen. The system is available both internal and external circulation.

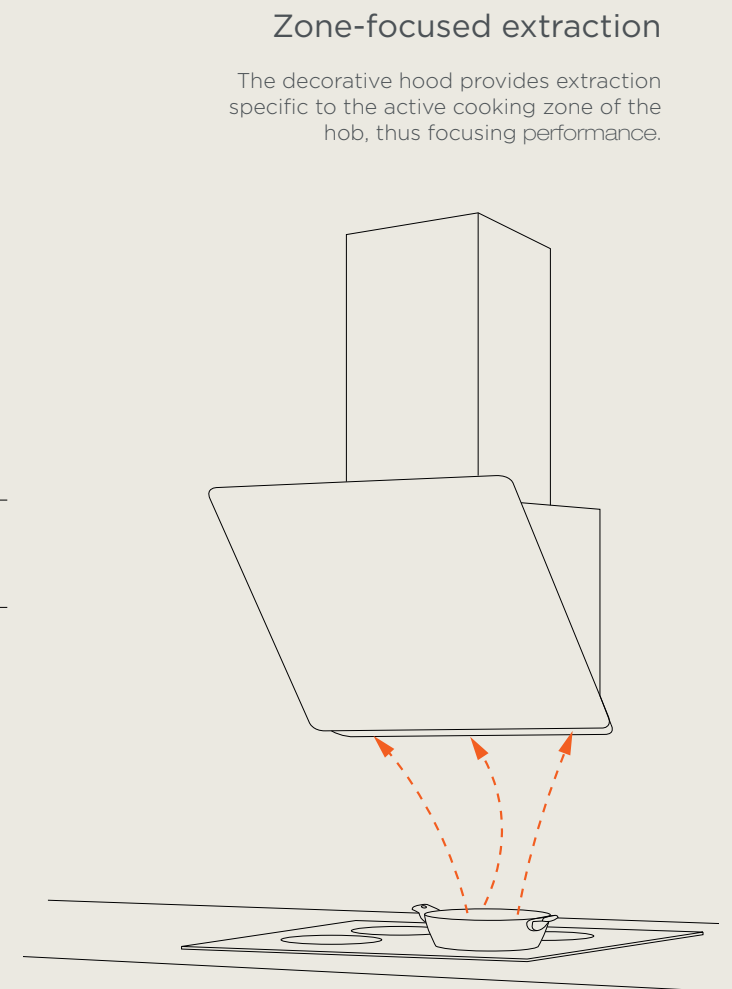

### Zone-focused extraction

The decorative hood provides extraction specific to the active cooking zone of the hob, thus focusing performance.

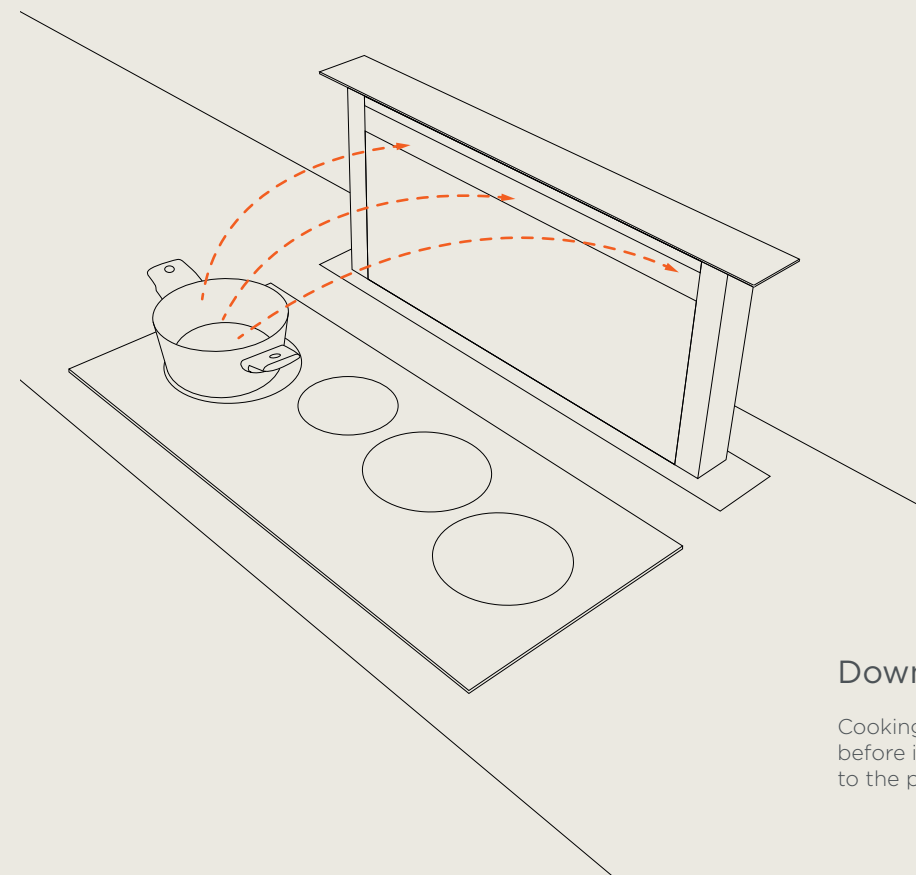

### Downdraft extraction

Cooking fume is extracted immediately before it disperses into the kitchen thanks to the practical countertop installation.

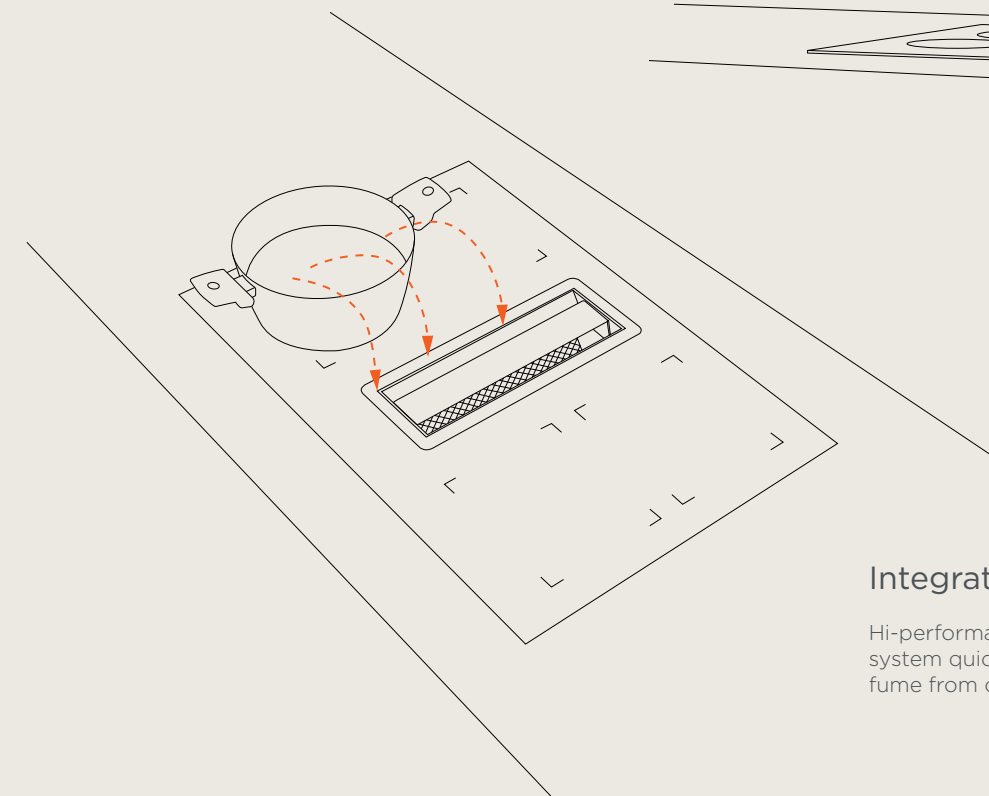

### Integrated extraction

Hi-performance extraction system quickly removes the fume from cooking surface



# hi<sup>+</sup> Series

THE TECHNOLOGY THAT MAKES LIFE EASIER IN THE KITCHEN: **SILVERINE HI!**

Whit the smart Hi application by Silverline, control your appliances in your kitchen from anywhere

Say hi to hi<sup>+</sup>

Welcome to High Intelligence kitchen experience.

With the Hi app, you will have the lot and experience the convenience of controlling your appliances in the kitchen any place you'd like. What awaits you is a unique kitchen experience that will make your life easier with many features offered by the smart Hi world.

## Adjust The Height

It is possible to adjust the hood height up and down. When not in use, it is raised to lock like a ceiling fixture.

## Led Ambient

You can enjoy your kitchen ambiance by changing the light of your hood & the ambience lighting on the ceiling with RGB and Tunable White mode via the App or with Alexa

## Filter Replacement Time

It informs you when it is time to clean or replace the grease and carbon filter. This esures that the high efficiency of your product is maintained.

## Air Quality is Continuously Monitored

Equipped with superior air quality sensors, Silverline Hi products keep the air quality maximized at all times.

- Simultaneous working of appliances in the kitchen
- Application control (iOS & Android)
- Filter life cycle reminding indicator (carbon filter & grease filter)
- Flavourful recipes for every taste
- Air quality sensor
- Humidity & Temperature sensor
- Voice control (With Alexa)



**SILVERLINE**  
**Perfect**  
**ION**



A Nano-Silver technology against the viruses and bacteria in your kitchen:  
**Silverline PerfectION**

Oil, fat and food residues in the kitchen can cause bacteria. Since we spend a lot of time in the kitchen and our foods touch many surfaces, it is important to ensure maximum hygiene in the kitchen.

Silverline PerfectION coats all the glass and metal surfaces of the products during production. It access the DNA and RNA codes of all the bacteria, fungi and viruses on the surfaces to eliminate them and ensures maximum hygiene.

**Continuous hygiene is possible:  
 Silverline PerfectION**

It is up to you to ensure that this level of hygiene continuous, both on Silverline products that are carefully sanitized and packaged after production, and later on in your kitchen. To ensure maximum hygiene against viruses and bacteria, all you need to do is use the PerfectION spray every 6 months. You can apply the PerfectION spray on all glass and metal surfaces of your Silverline products.



**What is Silverline PerfectION?**

Nano-silver ensures long-term antiviral and antibacterial effect on all surfaces.

- It kills both viruses and bacteria.
- It falls into the category of wide-spectrum high-level disinfectants thanks to the long-term effect it has.
- It kills enveloped and non-enveloped viruses as well as all gram positive and negative pathogens.

**Does PerfectION contain any harmful chemical allergens?**

Nano-silver is considered a natural antibiotic in global literature. The World Health Organization tolerates up to 100 ppm of silver in potable water..

**What is the application duration for Silverline PerfectION?  
 When can we start to use the area?**

The application duration is 10 to 15 minutes for an area of 100 m<sup>2</sup>. 10 minutes later, a layer of mist rolls in to stick to all surfaces and get activated.

**Is any preparation necessary before the application?**

It is recommended not to leave exposed food in the application area. Open the cabinet doors to ensure that the inside of them are sanitized as well.

**How often Silverline PerfectION should be applied?**

The ideal frequency of application depends on the risk scope of each area. For Silverline products, it should be applied every 6 months to ensure maximum protection.

**Is it harmful to pets?**

According to the standards of the World Health Organization, 100 ppm of silver is tolerable in potable water. Nano Clear AG+ has 80 ppm. There is no side effect in case of inhalation or skin contact.

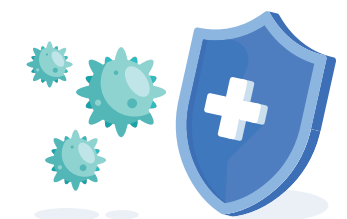

**YT950.1000.55**  
**YT950.1000.56**  
**YT950.1000.57**

# Energy Class

A+++ | A++ | A+ | A | B | C | D



55cm

## HOB DISTANCE (ELECTRIC)

The distance between electric hob and hood.



65cm

## HOB DISTANCE (GAS)

The distance between gas hob and hood.



## CARBON FILTER

It makes sure your kitchen is kept odour-free. The filter filtrates vapours and grease created by cooking.



## REMOTE CONTROL

Control with a functional remote controller.



## APP CONTROL

Control with IOS and/or Android applications.



## SILVER CONNECT

Automatic adjustment of the hood speed according to the air flow by the cooker with Bluetooth.



## EASY INSTALLATION

Easy installation of hoods via spending less time and energy

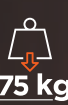

75 kg

## WEIGHT

The weight of hood.



## LIGHTING (STANDARD)

The halogen lamp has high efficiency, quality of light, and high rated life.



## LED LIGHTING

Provides higher brightness with lower energy.



## LED STRIPE LIGHTING

Provides flexibility and color options which make it perfectly suited for many lighting applications.



## RGB LED LIGHTING

The color of the light is adjusted with the remote control.



## TUNABLE LED LIGHTING

Temperature value of white color.



## AUTOMATIC SENSORS

Automatic control for the functions.



## CUSTOMISATION

Provides panel options according to the customer's preference.



## AUTO MODE

Automatic hood system operating simultaneously with the hob for worktop hoods.



## HI SERIES

Guarantees brilliant cooking experience and fresh air by Hi technologies.



## MANUAL MODE

Manual control of hood functions.



V12 IQ

## V12 DYNAMIC IQ MOTOR

New generation engine technology with high energy efficiency, air extraction performance and very low noise level.



## ACTIVE FLEX CARBON FILTER

Flexible carbon filter that allows easy usage and replacement.



V12 AC

## HE V12 DYNAMIC IQ MOTOR

New generation engine technology with high energy efficiency, air extraction performance and very low noise level.



## FILTER LIFECYCLE INDICATOR

Alerts when filters are due for replacement.



## PLUG & PLAY

Easy installation without pipe kit.



## FULL SURFACE LIGHTING

Creates a brighter kitchen environment.



## AIR QUALITY INDICATOR

Air quality feedback to keep ambient air quality at the best level and automatic function.



## LIFT

Adjustable height for the hood.



2L

## WASTE WATER CAPACITY

Maximum waste water capacity of the product.



## AUTO FUNCTION

It enables the product to work automatically thanks to the data it receives from the sensors.



## SILVERMUTE

Products with a whisper-level sound.



## USING WITH PIPE

Usage with pipe for worktop hoods.



## STEAM SENSOR

It detects the steam and ensures that the hood works automatically.



## WORKTOP HOODS

The integrated hood in hob extracts unpleasant odors and steam emitted during cooking directly from the source. This ensures continued clean air flow in the kitchen.

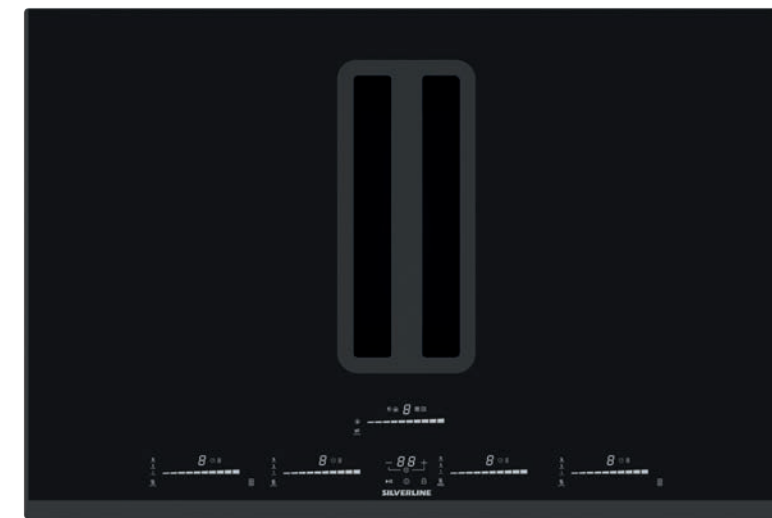

## 7170 FLOW-IN PRO X BLW



### Hood

#### Technical Data

Category	Worktop Hoods
Size	78-85
Duct Out Version	Intern (Duct Out / Recirculation)
Finish	Inox + Tempered Glass

#### Performance Data

Max Flow Rate	610 (m <sup>3</sup> /h)
Max Noise Level	69 dB(A)
Total Absorption	240W
Filter	U-Shaped Black Grease Filter + Optional Active Flex Carbon Filter + Optional Helsa Filter
Control	Smart Control 96+B
Lighting	/
Duct Size	220x89 mm

### Hob

#### Technical Data

Power Stage Setting	9 Levels
Booster	4 Boosters
Bridge	Double
Residual Heat Indicator	"H"
Keep Warm	Yes
Timer	Yes
Automatic Safety Switch Off	90 Min
Child Lock	Yes
Pause and Recall	Yes
Voltage	220-240V
Frequency	50 / 60Hz
Control	Multi Slider
Coil Type	Octa Flex
Hob Type	Induction Hob
Coil Size & Power	2 (2kW - 2.8kW) - 190*190mm 2 (1.5kW - 2kW) - 190*190mm
Total Power	7.4 kW
Power Limitation	2,8kW - 3,5kW - 7,4kW

#### Hob Colors



Black

#### Grill Colors



Black

#### Grease Filter Colors



Black



Inox



Orange

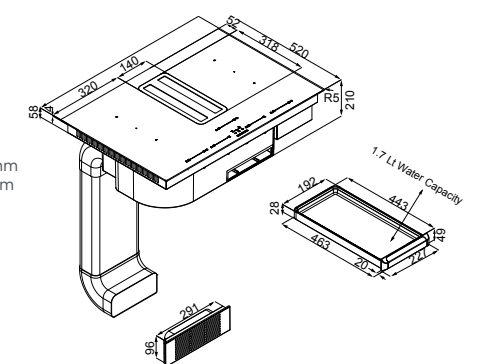

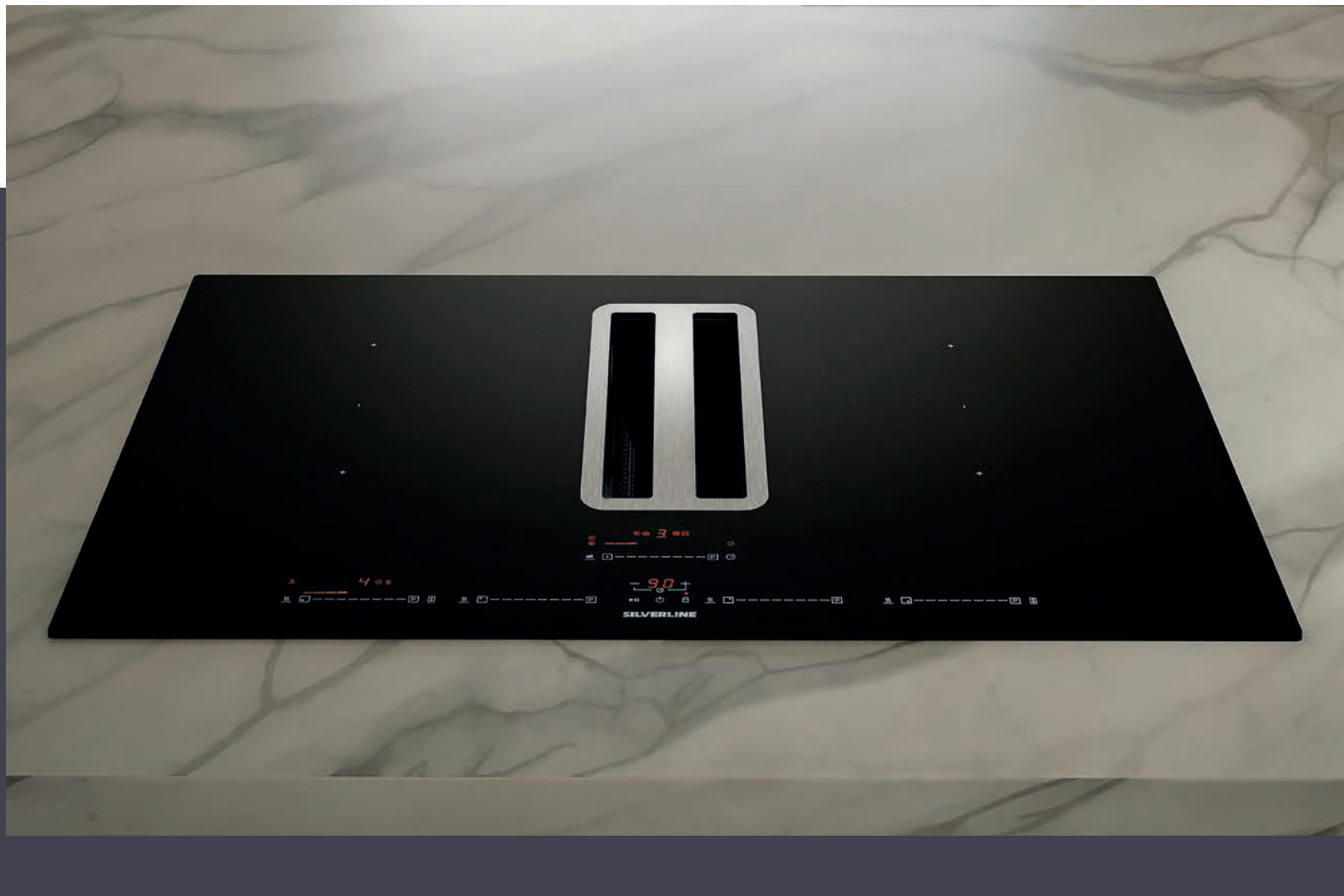

## 7170 FLOW-IN PRO X



### Installation instructions:

Whit Drawer:

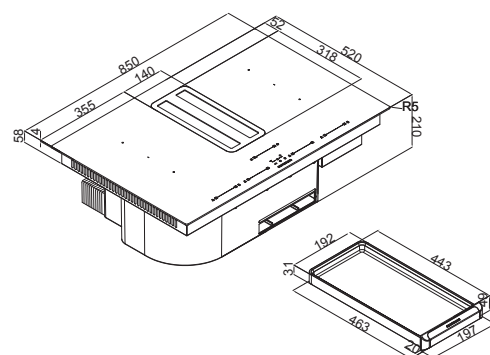

Whitout Drawer:

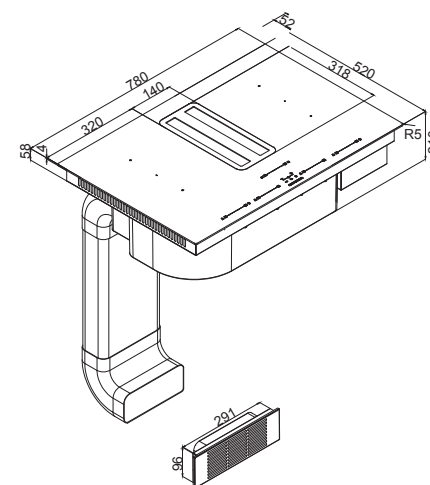

#### Hood

##### Technical Data

Category	Worktop Hoods
Size	78-85
Duct Out Version	Intern (Duct Out / Recirculation)
Finish	Inox + Tempered Glass

##### Performance Data

Max Flow Rate	610 (m <sup>3</sup> /h)
Max Noise Level	69 dB(A)
Total Absorbation	240W
Filter	U-Shaped Black Grease Filter + Optional Active Flex Carbon Filter + Optional Helsa Filter
Control	Multi slider 96+B
Lighting	/
Duct Size	220x89 mm

#### Hob

##### Technical Data

Power Stage Setting	9 Levels
Booster	4 Boosters
Bridge	Double
Residual Heat Indicator	"H"
Keep Warm	Yes
Timer	Yes
Automatic Safety Switch Off	90 Min
Child Lock	Yes
Pause and Recall	Yes
Voltage	220-240V
Frequency	50 / 60Hz
Control	Multi Slider
Coil Type	Octa Flex
Hob Type	Induction Hob
Coil Size & Power	2 (2kW - 2.8kW) - 190*190mm 2 (1.5kW - 2kW) - 190*190mm
Total Power	7.4 kW
Power Limitation	2.8kW - 3.5kW - 7.4kW

#### Hob Colors



Black

#### Grill Colors



Black

#### Grease Filter Colors



Black



Inox



Orange

# WORKTOP HOODS



## 7170 FLOW-IN PRO X WHT

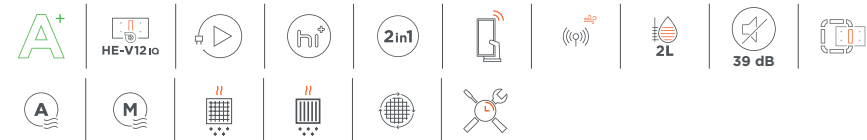

### Hood Technical Data

Category	Worktop Hoods
Size	78-85cm
Duct Out Version	Intern (Duct Out / Recirculation)
Finish	Inox + Tempered Glass

### Performance Data

Max Flow Rate	610 (m³/h)
Max Noise Level	69 dB(A)
Total Absorption	240W
Filter	U-Shaped Black Grease Filter + Optional Active Flex Carbon Filter + Optional Helsa Filter
Control	Multi slider 96+B
Lighting	/
Duct Size	220x89 mm

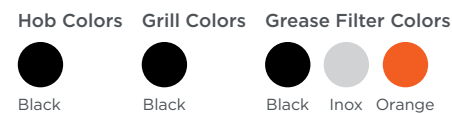

### Hob Technical Data

Power Stage Setting	9 Levels
Booster	4 Boosters
Bridge	Double
Residual Heat Indicator	"H"
Keep Warm	Yes
Timer	Yes
Automatic Safety Switch Off	90 Min
Child Lock	Yes
Pause and Recall	Yes
Voltage	220-240V
Frequency	50 / 60Hz
Control	Multi Slider
Coil Type	Octa Flex
Hob Type	Induction Hob
Coil Size & Power	2 (2kW - 2.8kW) - 190*190mm 2 (1.5kW - 2kW) - 190*190mm
Total Power	7.4 kW
Power Limitation	2,8kW - 3,5kW - 7,4kW

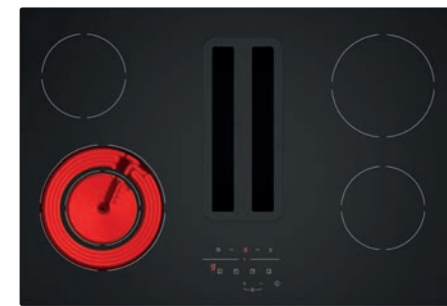

## 7210 FLOW IN PRO X HIGHLIGHT



### Hood Technical Data

Category	Worktop Hoods
Size	78cm
Duct Out Version	Intern (Duct Out / Recirculation)
Finish	Ceramic Glass

### Performance Data

Max Flow Rate	500 (m³/h)
Max Noise Level	68 dB(A)
Total Absorption	240W
Filter	U-Shaped Black Grease Filter + Optional Active Flex Carbon Filter + Optional Helsa Filter
Control	Touch control
Lighting	/
Duct Size	220x89 mm

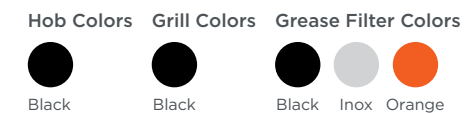

### Hob Technical Data

Power Stage Setting	9 Levels
Booster	No
Bridge	No
Residual Heat Indicator	"H"
Keep Warm	No
Timer	No
Automatic Safety Switch Off	90 Min
Child Lock	Yes
Pause and Recall	No
Voltage	220-240V
Frequency	50 / 60Hz
Control	Touch Control
Coil Type	Radial Round
Hob Type	Vitrocamic Hob
Coil Size & Power	1 (2.25kW - 11.5kW) - ø210mm (Dual Zone) 1 (1.8kW) - ø180mm 2 (1.2kW) - ø145mm
Total Power	6.6 kW
Power Limitation	No



# WORKTOP HOODS

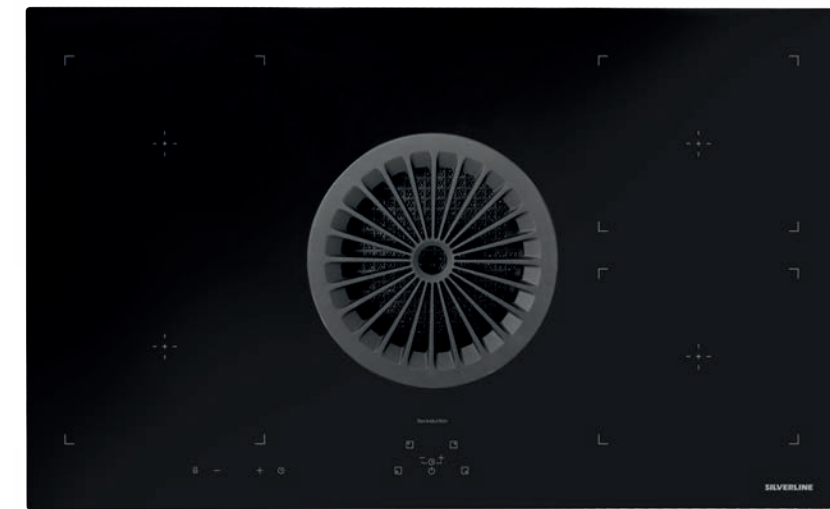

## 3412 SUPREME



### Technical Data

Category	Worktop Hoods
Size	85cm
Duct Out Version	Intern (Duct Out / Recirculation)
Finish	Aluminium + Tempered Glass

### Performance Data

Max Flow Rate	648 m <sup>3</sup> /h
Max Noise Level	59 dB(A)
Total Absorption	150W
Filter	Stainless Steel Conic Filter + Active Carbon Filter
Control	4S Touch Control
Lighting	/
Duct Size	220x89mm

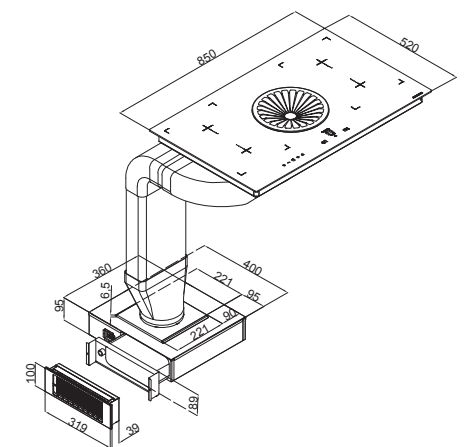



# WORKTOP HOODS



## 3416 FREE FLOW

### Technical Data

Category	Worktop Hoods
Size	40cm
Duct Out Version	Intern (Duct Out / Recirculation)
Finish	Inox

### Performance Data

Max Flow Rate:	723 m <sup>3</sup> /h
Max Noise Level:	66 dB(A)
Total Absorption:	150W
Filter	Stainless Steel Cassette Filter + Active Carbon Filter
Control	3S+1B Touch Control
Lighting	/
Duct Size	220x89mm

### Color



Inox

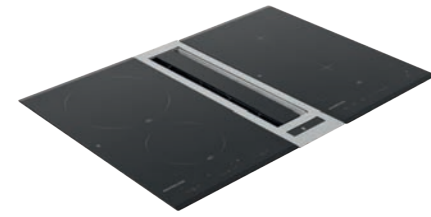
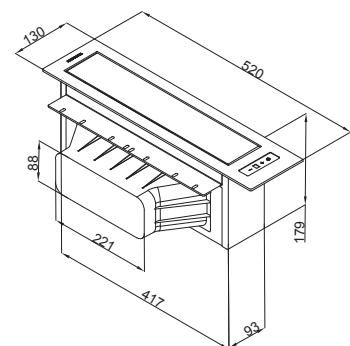

## 3417 DOUBLE FLOW

### Technical Data

Category	Worktop Hoods
Size	40cm
Duct Out Version	Intern (Duct Out / Recirculation)
Finish	Inox + Tempered Glass

### Performance Data

Max Flow Rate:	577 m <sup>3</sup> /h
Max Noise Level:	71 dB(A)
Total Absorption:	150W
Filter	Stainless Steel Cassette Filter + Active Carbon Filter
Control	4S Touch Control
Lighting	/
Duct Size	220x89mm

### Color



Inox

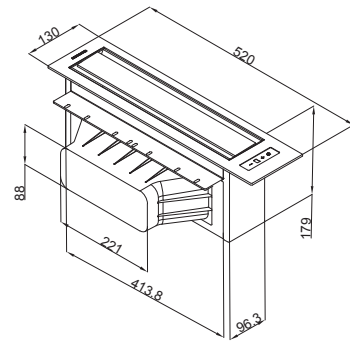

# MODULAR SYSTEM



## MODULAR HOB OPTIONS

IH8120B01



VC8220B01





## WORKTOP HOODS

### 3410 DOWNDRAFT



#### Technical Data

Category	Worktop Hoods
Size	60 - 90 - 120cm
Duct Out Version	Intern (Duct Out / Recirculation)
Finish	Inox + Tempered Glass

#### Performance Data

Max Flow Rate:	813 m <sup>3</sup> /h
Max Noise Level:	62 dB(A)
Total Absorption:	282W
Filter	Stainless Steel Cassette Filter + Active Carbon Filter
Control	3S+1B Touch Control
Lighting	4x1,1W Power LED
Duct Size	150mm

Color



Black

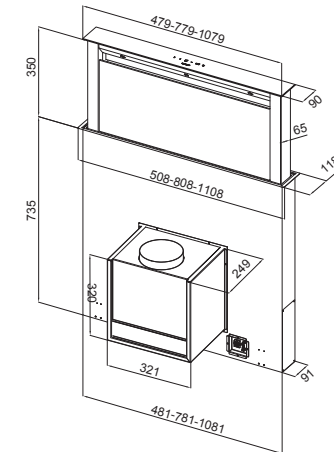

# SUSPENDED HOODS



# LIGHTLINE

## EYE-CATCHING ELEGANT DESIGN

The glass and thin aluminum frame combine with the light to provide stylish lighting. At the same time, it reflects the light perfectly with its smooth matte finish.

STRIKING COLORS THAT REFLECT ON THE CEILING

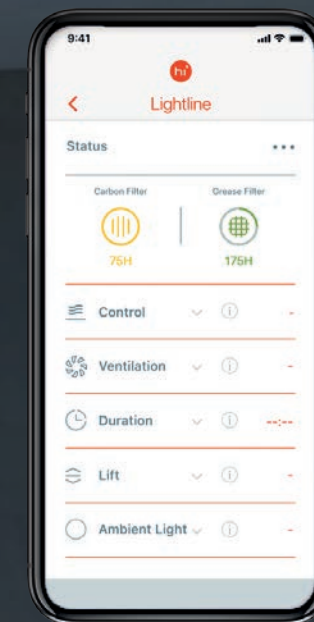

## EASE OF USE WITH THE MOBILE APPLICATION

The mobile app can control the main functions of the hood such as airflow rate, lighting, up and down movements. It is also possible to use the application to adjust the tone of the functional lighting and change the color of the ambient lighting.



### Hob2Hood

Smart system providing  
hood and hob connection



### Lift

Adjustable height up to  
1.10 m with mobile app



## SUSPENDED HOODS



## 4390 LIGHTLINE



### Technical Data

Category	Suspended Hood
Size	120 cm
Duct Out Veraiion	Intern (Recirculation)
Finish	Inox + Tempered Glass

### Performance Data

Max Flow Rate	600 m <sup>3</sup> /h
Max Noise Level	58 dB(A)
Total Absorption	247 W
Filter	Aluminium Cassette Filter + Active Carbon Filter
Control	Application + Remote Control
Lighting	87W LED Stripe (RGB + TW)

### Color

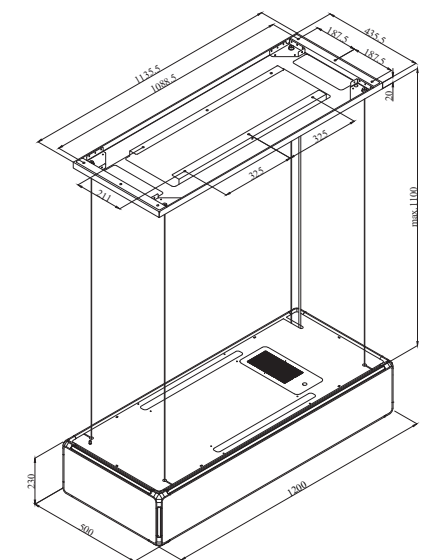

# SUSPENDED HOODS



## 4391

### Technical Data

Category	Suspended Hoods
Size	40cm
Duct Out Version	Intern (Duct Out / Recirculation)
Finish	Inox + Tempered Glass

### Performance Data

Max Flow Rate:	738 m <sup>3</sup> /h
Max Noise Level:	59 dB(A)
Total Absorption:	362W
Filter	Aluminium Cassette Filter + Optional Carbon Filter
Control	3S+1B Smart Touch Control +App
Lighting	87W LED Stripe (TW)
Duct Size	/

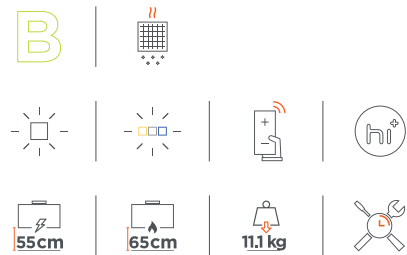
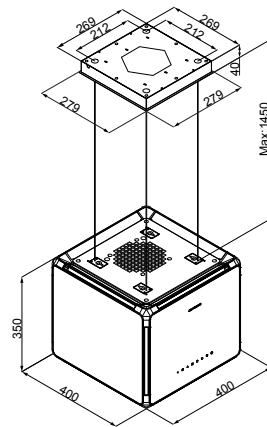
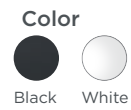

## 4386 PURE PLUS

### Technical Data

Category	Suspended Hoods
Size	50cm
Duct Out Version	Intern (Recirculation)
Finish	Inox + Tempered Glass

### Performance Data

Max Flow Rate:	765 m <sup>3</sup> /h
Max Noise Level:	64 dB(A)
Total Absorption:	280W
Filter	Stainless Steel Cassette Filter + Active Carbon Filter
Control	2S+1B Touch Control
Lighting	2x2,5W D-LED
Duct Size	/

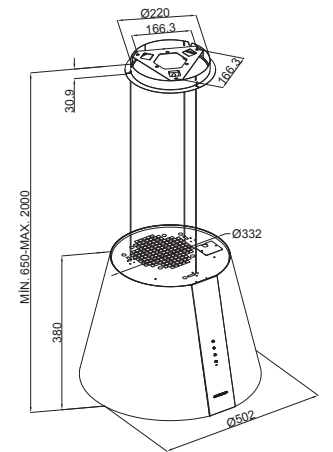
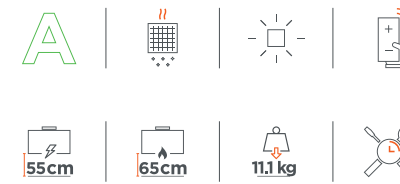

## 4388 ETAN

### Technical Data

Category	Suspended Hoods
Size	40cm
Duct Out Version	Intern (Duct Out / Recirculation)
Finish	Inox + Tempered Glass

### Performance Data

Max Flow Rate:	655 m <sup>3</sup> /h
Max Noise Level:	59 dB(A)
Total Absorption:	278W
Filter	Aluminium Cassette Filter + Optional Carbon Filter
Control	3S+1B Soft Remote Control
Lighting	2x1,5W G4 LED
Duct Size	/

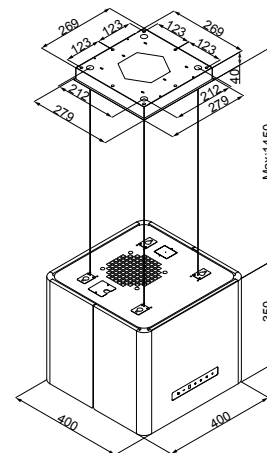
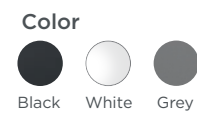

## 4386 XSMALL

### Technical Data

Category	Suspended Hoods
Size	40cm
Duct Out Version	Intern (Recirculation)
Finish	Inox + Tempered Glass

### Performance Data

Max Flow Rate:	335 m <sup>3</sup> /h
Max Noise Level:	64 dB(A)
Total Absorption:	90W
Filter	Stainless Steel Cassette Filter + Active Carbon Filter
Control	2S+1B Touch Control
Lighting	2x2,5W D-LED
Duct Size	/

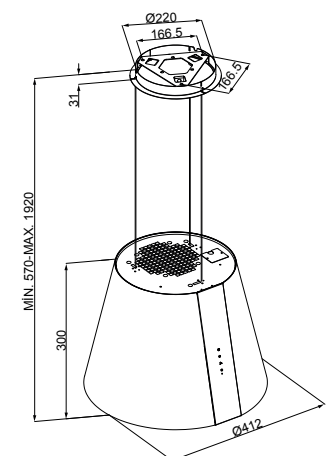
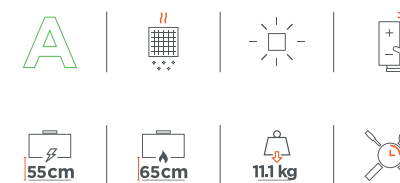

# ISLAND HOODS







# ISLAND HOODS

## 4207



### Technical Data

Category Island Hoods  
 Size 90cm  
 Duct Out Version Intern (Duct Out / Recirculation)  
 Finish Inox + Tempered Glass

### Performance Data

Max Flow Rate: 738 m<sup>3</sup>/h  
 Max Noise Level: 62 dB(A)  
 Total Absorption: 274W  
 Filter Stainless Steel Casette Filter + Charcoal Carbon Filter  
 Control 3S+1B Touch Control  
 Lighting 2x4,5W LED Stripe  
 Duct Size 150mm

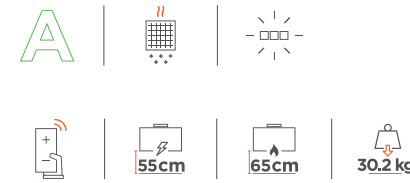

### Color

Black White

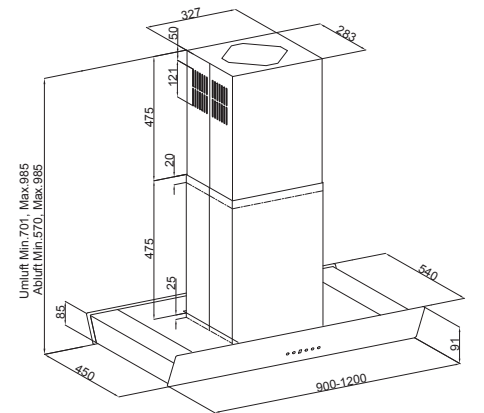

## 4203



### Technical Data

Category Island Hoods  
 Size 90cm  
 Duct Out Version Intern (Duct Out / Recirculation)  
 Finish Inox + Tempered Glass

### Performance Data

Max Flow Rate: 702 m<sup>3</sup>/h  
 Max Noise Level: 63 dB(A)  
 Total Absorption: 279W  
 Filter Aluminium Casette Filter + Optional Carbon Filter  
 Control 4S+1B Touch Control  
 Lighting 4x1,5W G4 LED  
 Duct Size 150mm

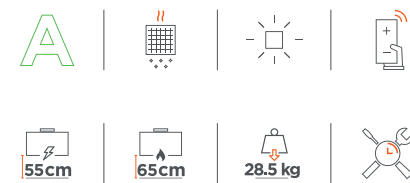

### Color

Inox

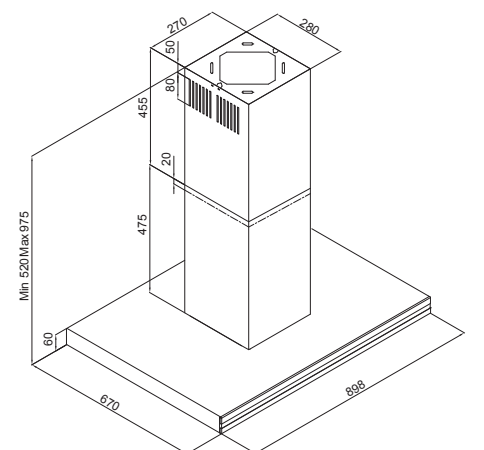

# ISLAND HOODS

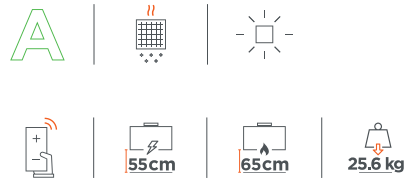

## 4250

### Technical Data

Category	Island Hoods
Size	60 - 90cm
Duct Out Version	Intern (Duct Out / Recirculation)
Finish	Inox + Tempered Glass

### Performance Data

Max Flow Rate:	747 m <sup>3</sup> /h
Max Noise Level:	64 dB(A)
Total Absorption:	281W
Filter	Aluminium Casette Filter + Optional Carbon Filter
Control	3S+1B Soft Touch with Display
Lighting	4x1,5W G4 LED
Duct Size	150mm

### Color

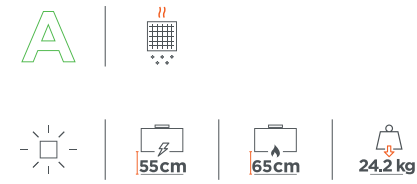
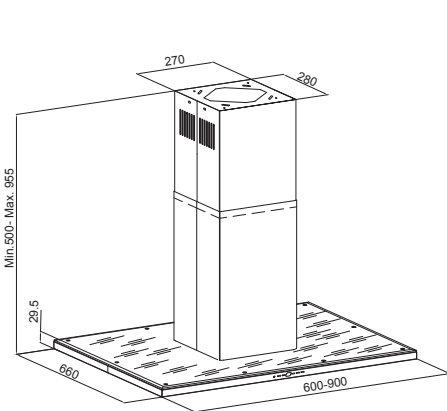
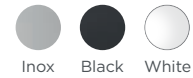

## 4110

### Technical Data

Category	Island Hoods
Size	60 - 90cm
Duct Out Version	Intern (Duct Out / Recirculation)
Finish	Inox

### Performance Data

Max Flow Rate:	765 m <sup>3</sup> /h
Max Noise Level:	62 dB(A)
Total Absorption:	278W
Filter	Aluminium Casette Filter + Optional Carbon Filter
Control	3S+1B Soft Touch with Display
Lighting	2x1,5W G4 LED
Duct Size	150mm

### Color

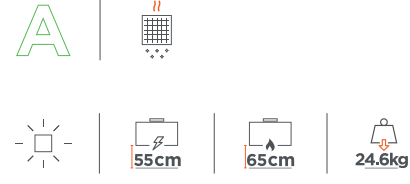
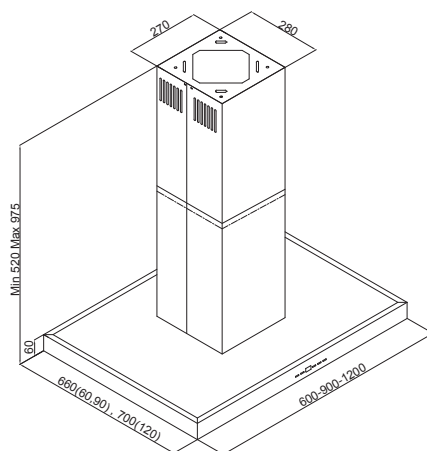
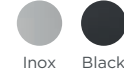

## 4140

### Technical Data

Category	Island Hoods
Size	90cm
Duct Out Version	Intern (Duct Out / Recirculation)
Finish	Inox + Tempered Glass

### Performance Data

Max Flow Rate:	750 m <sup>3</sup> /h
Max Noise Level:	65 dB(A)
Total Absorption:	278W
Filter	Aluminium Casette Filter + Optional Carbon Filter
Control	3S+1B Soft Touch with LCD
Lighting	2x1,5W G4 LED
Duct Size	150mm

### Color

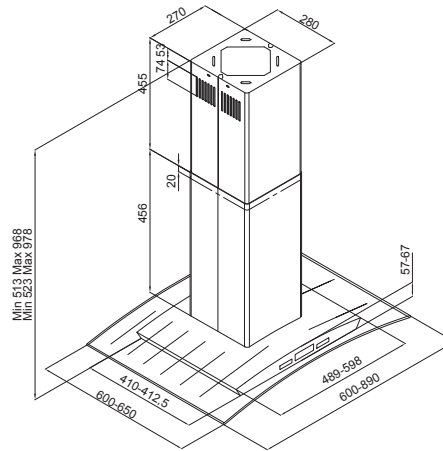

## 4170

### Technical Data

Category	Island Hoods
Size	40cm
Duct Out Version	Intern (Duct Out / Recirculation)
Finish	Inox

### Performance Data

Max Flow Rate:	739 m <sup>3</sup> /h
Max Noise Level:	63 dB(A)
Total Absorption:	278W
Filter	Aluminium Casette Filter + Optional Carbon Filter
Control	3S+1B Soft Touch with Display
Lighting	2x1,5W G4 LED
Duct Size	150mm

### Color

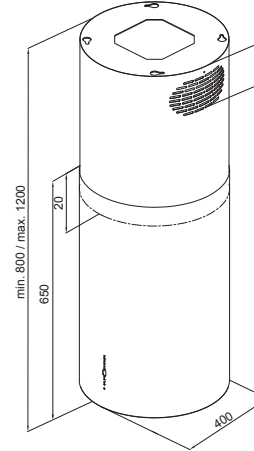

## 4180

### Technical Data

Category	Island Hoods
Size	40cm
Duct Out Version	Intern (Duct Out / Recirculation)
Finish	Inox

### Performance Data

Max Flow Rate:	700 m <sup>3</sup> /h
Max Noise Level:	54 dB(A)
Total Absorption:	269W
Filter	Aluminium Casette Filter + Optional Carbon Filter
Control	4S+1B Soft Touch with Display
Lighting	2x1,5W G4 LED
Duct Size	150mm

### Color

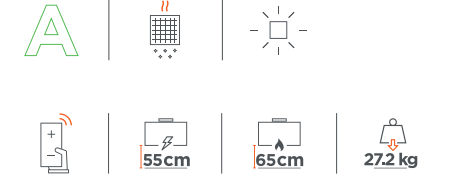
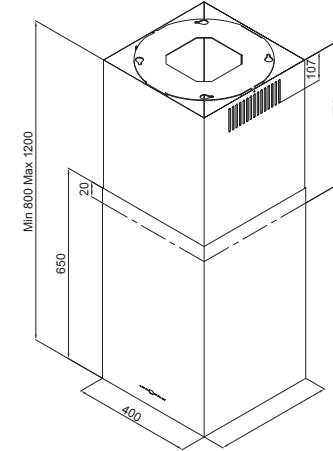

## 4204

### Technical Data

Category	Island Hoods
Size	90cm
Duct Out Version	Intern (Duct Out / Recirculation)
Finish	Inox + Tempered Glass

### Performance Data

Max Flow Rate:	741 m <sup>3</sup> /h
Max Noise Level:	64 dB(A)
Total Absorption:	289W
Filter	Stainless Steel Casette Filter + Charcoal Carbon Filter
Control	3S+1B Touch Control
Lighting	14W Power LED
Duct Size	150mm

### Color

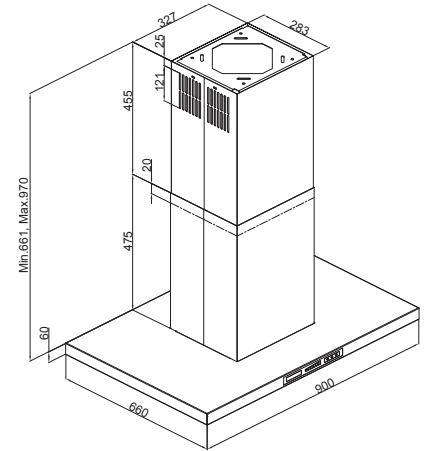

# CEILING HOODS

Ceiling-mounted extractor hoods by Silverline are designed to meet consumer needs and expectations by combining elegance and functionality with the aim of turning modern kitchens into comfortable living spaces.





## 4260 NIGHT

### Technical Data

Category	Ceiling Hoods
Size	90cm
Duct Out Version	Extern / Intern (Duct Out Recirculation)
Finish	Tempered Glass

### Performance Data

Max Flow Rate:	758 m <sup>3</sup> /h
Max Noise Level:	62 dB(A)
Total Absorption:	290W
Filter	Aluminium Cassette Filter + Optional Carbon Filter
Control	3S+1B Remote Control
Lighting	15W Micro LED
Duct Size	150mm

### Color



Black White

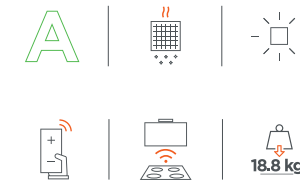
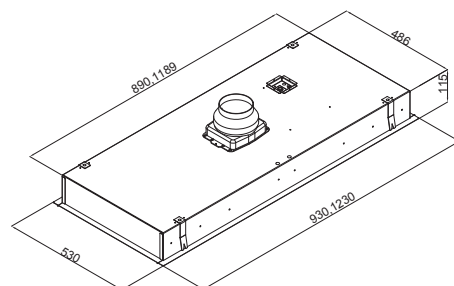
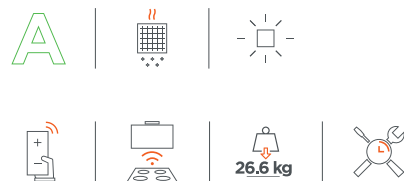

## 4229

### Technical Data

Category	Ceiling Hoods
Size	90 - 120cm
Duct Out Version	Extern / Intern (Duct Out Recirculation)
Finish	Tempered Glass

### Performance Data

Max Flow Rate:	773 m <sup>3</sup> /h
Max Noise Level:	61 dB(A)
Total Absorption:	306W
Filter	Aluminium Cassette Filter + Optional Carbon Filter
Control	3S+1B Remote Control
Lighting	3x3,5W LED
Duct Size	150mm

### Color



Black White



## 4227 ROOF

### Technical Data

Category	Ceiling Hoods
Size	100 - 120cm
Duct Out Version	Extern
Finish	Tempered Glass

### Performance Data

Max Flow Rate:	786 m <sup>3</sup> /h
Max Noise Level:	60 dB(A)
Total Absorption:	/
Filter	Aluminium Cassette Filter
Control	2S+2B Remote Control
Lighting	/
Duct Size	150mm

### Color



Inox Black White

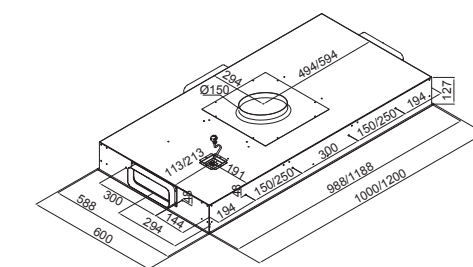

# CEILING HOODS



## 4224

### Technical Data

Category	Ceiling Hoods
Size	100 - 120cm
Duct Out Version	Extern / Intern (Duct Out Recirculation)
Finish	Inox + Tempered Glass

### Performance Data

Max Flow Rate:	476 m <sup>3</sup> /h
Max Noise Level:	71 dB(A)
Total Absorption:	338W
Filter	Stainless Steel Cassette Filter + Active Carbon Filter
Control	3S+1B Remote Control
Lighting	6x3W LED
Duct Size	/

### Color



Inox+Black Inox+White

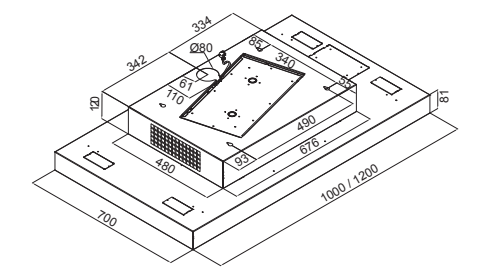

# CEILING HOODS



4261

## Technical Data

Category	Ceiling Hoods
Size	60 -70 - 90cm
Duct Out Version	Intern (Duct Out / Recirculation)
Finish	Inox + Tempered Glass

## Performance Data

Max Flow Rate:	727 m <sup>3</sup> /h
Max Noise Level:	56 dB(A)
Total Absorption:	204W
Filter	Aluminium Cassette Filter
Control	3S+B Touch Control
Lighting	9W LED Stripe
Duct Size	150 mm

## Color



Black White

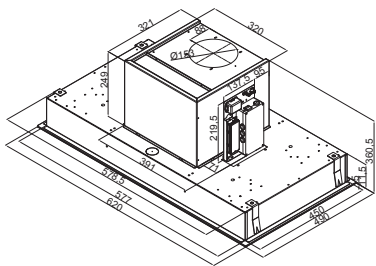

4262 SYKDOOR

## Technical Data

Category	Ceiling Hoods
Size	100 - 120cm
Duct Out Version	Extern / Intern (Duct Out / Recirculation)
Finish	Inox + Tempered Glass

## Performance Data

Max Flow Rate:	649 m <sup>3</sup> /h
Max Noise Level:	68 dB(A)
Total Absorption:	137W
Filter	Stainless Steel Cassette Filter + Active Carbon Filter
Control	4S Remote Control
Lighting	1x35W
Duct Size	/

## Color



White

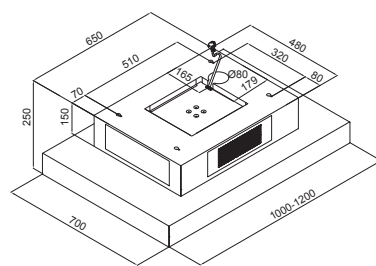

4266 SLIDE TO HEAVEN

## Technical Data

Category	Ceiling Hoods
Size	100 - 120cm
Duct Out Version	Extern / Intern (Duct Out / Recirculation)
Finish	Inox + Tempered Glass

## Performance Data

Max Flow Rate:	590 m <sup>3</sup> /h
Max Noise Level:	76 dB(A)
Total Absorption:	132W
Filter	Stainless Steel Cassette Filter + Active Carbon Filter
Control	4S Remote Control
Lighting	1x32W LED Stripe
Duct Size	/

## Color



Black White

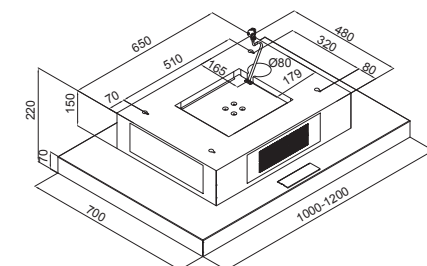

4264 SQUARE BOX

## Technical Data

Category	Ceiling Hoods
Size	100 - 120cm
Duct Out Version	Intern (Duct Out / Recirculation)
Finish	Inox + Tempered Glass

## Performance Data

Max Flow Rate:	578 m <sup>3</sup> /h
Max Noise Level:	73 dB(A)
Total Absorption:	137W
Filter	Stainless Steel Cassette Filter + Active Carbon Filter
Control	4S Remote Control
Lighting	1x35W LED Stripe
Duct Size	/

## Color



Black White

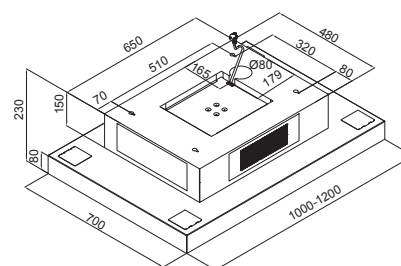

4263

## Technical Data

Category	Ceiling Hoods
Size	100 - 120cm
Duct Out Version	Intern (Duct Out / Recirculation)
Finish	Inox + Tempered Glass

## Performance Data

Max Flow Rate:	686 m <sup>3</sup> /h
Max Noise Level:	67 dB(A)
Total Absorption:	234W
Filter	Stainless Steel Cassette Filter + Active Carbon Filter
Control	3S+1B Remote Control
Lighting	1x30W LED Stripe
Duct Size	/

## Color



Black White

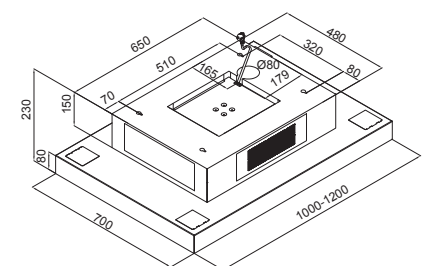

# WALL-MOUNTED HOODS

Silverline's wall-mounted hoods can serve as a design element in your kitchen, adding a distinctive look to your cook space depending on the product style you choose.





## WALL-MOUNTED HOODS



### 3491 MANHATTAN



#### Technical Data

Category	Wall Type Hoods
Size	60-90cm
Duct Out Version	Intern (Duct Out / Recirculation)
Finish	Inox + Tempered Glass

#### Performance Data

Max Flow Rate:	780 m <sup>3</sup> /h
Max Noise Level:	61 dB(A)
Total Absorption:	182W
Filter	Aluminium Cassette Filter + Optional Carbon Filter
Control	3S+B Smart Touch Control
Lighting	1x7W LED Stripe
Duct Size	150mm

#### Color



Black

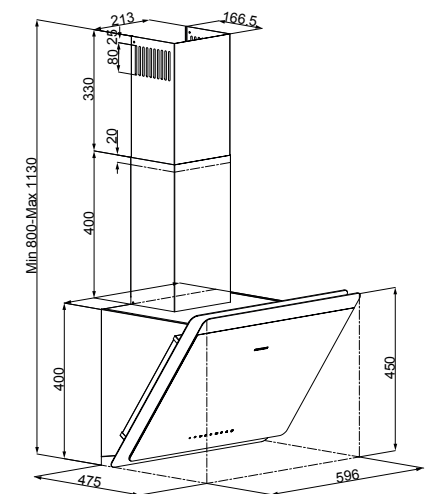

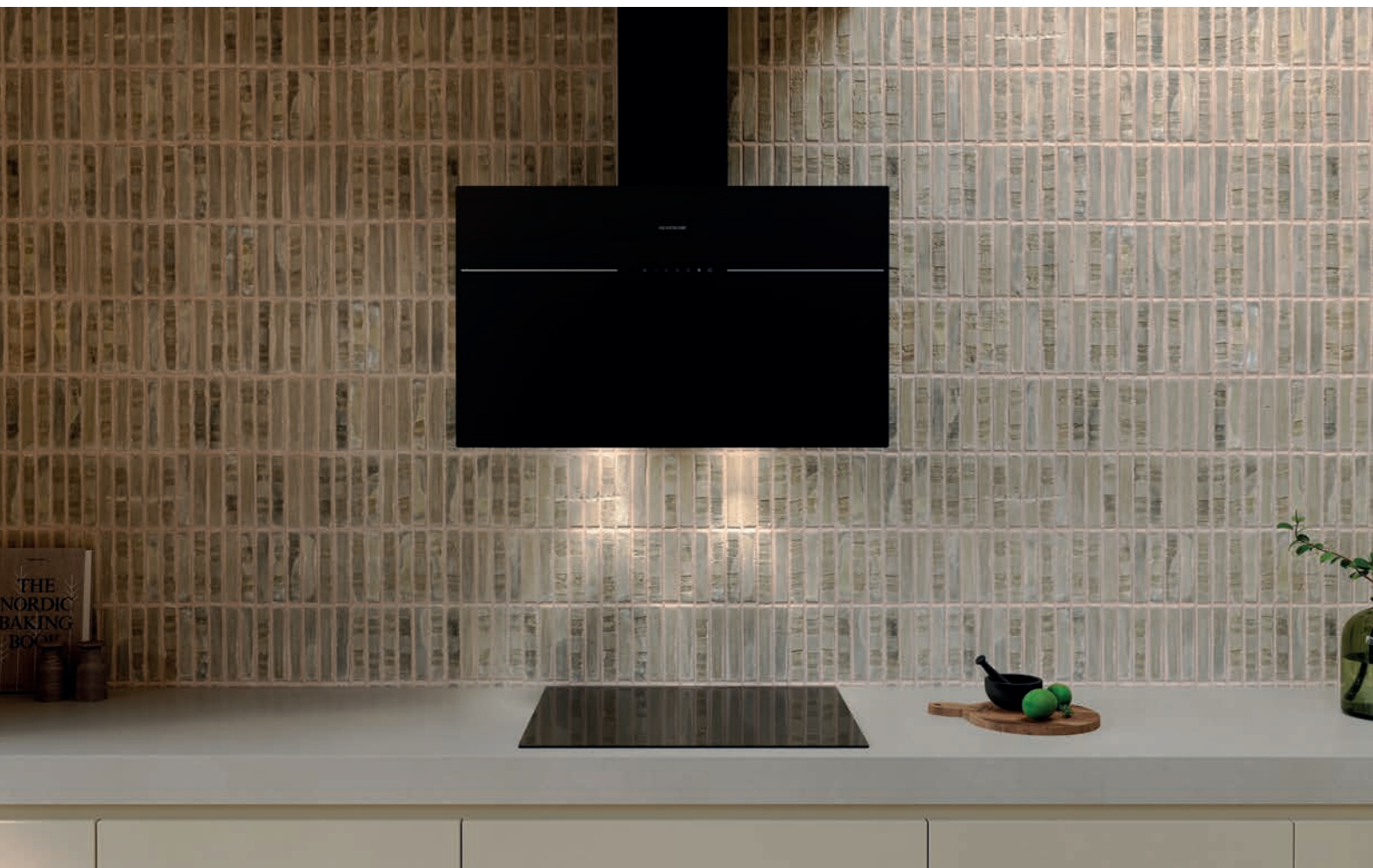

## 3364 LINK FLAT

### Technical Data

Category	Wall Type Hoods
Size	60-80cm
Duct Out Version	Intern (Duct Out / Recirculation)
Finish	Tempered Glass

### Performance Data

Max Flow Rate:	670m <sup>3</sup> /h
Max Noise Level:	57 dB(A)
Total Absorption:	216W
Filter	Aluminium Cassette Filter + Optional Carbon Filter
Control	Touch Control
Lighting	2x3W LED
Duct Size	150mm

### Color

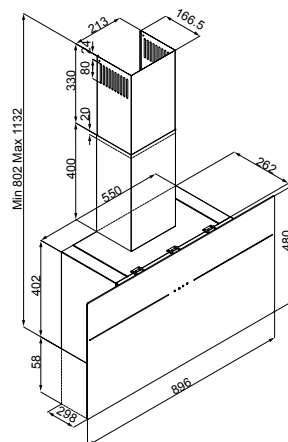

## 3457 LINK INCLINED

### Technical Data

Category	Wall Type Hoods
Size	60-80-90cm
Duct Out Version	Intern (Duct Out / Recirculation)
Finish	Inox + Tempered Glass

### Performance Data

Max Flow Rate:	795m <sup>3</sup> /h
Max Noise Level:	62 dB(A)
Total Absorption:	281W
Filter	Aluminium Cassette Filter + Optional Carbon Filter
Control	Touch Control
Lighting	2x3W LED
Duct Size	150mm

### Color

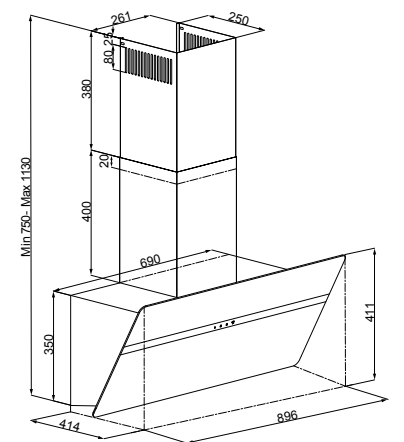



# WALL-MOUNTED HOODS



## 2262 LUNA



### Technical Data

Category	Wall Type Hoods
Size	80cm
Duct Out Version	Intern (Duct Out / Recirculation)
Finish	Inox + Tempered Glass

### Performance Data

Max Flow Rate:	673 m <sup>3</sup> /h
Max Noise Level:	61 dB(A)
Total Absorption:	130W
Filter	Aluminium Cassette Filter + Active Carbon Filter
Control	3S+B Smart Touch Control
Lighting	1,4x4W LED Stripe
Duct Size	150mm

### Color

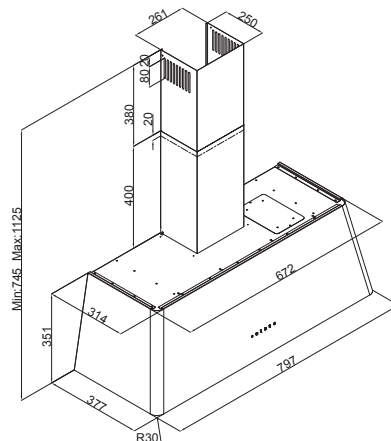

## 3481

### Technical Data

Category	Wall Type Hoods
Size	60-90cm
Duct Out Version	Intern (Duct Out / Recirculation)
Finish	Inox + Tempered Glass

### Performance Data

Max Flow Rate:	402m <sup>3</sup> /h
Max Noise Level:	64 dB(A)
Total Absorption:	123W
Filter	Aluminium Cassette Filter + Optional Carbon Filter
Control	3S Touch control
Lighting	2x1,5W Power LED
Duct Size	120mm

### Color

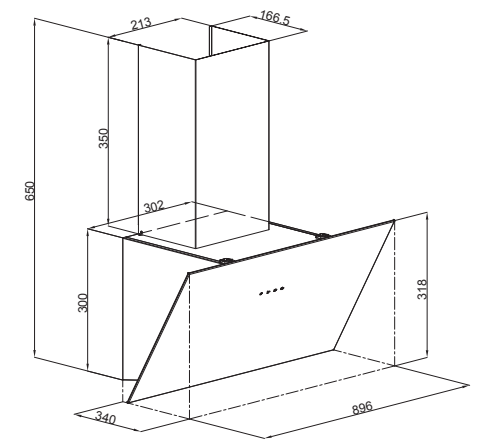

## 3333 DECTON

### Technical Data

Category	Wall Type Hoods
Size	60-80cm
Duct Out Version	Intern (Duct Out / Recirculation)
Finish	Dekton

### Performance Data

Max Flow Rate:	669 m <sup>3</sup> /h
Max Noise Level:	53 dB(A)
Total Absorption:	205W
Filter	Aluminium Cassette Filter + Optional Carbon Filter
Control	3S+B Touch Control
Lighting	10W Power LED
Duct Size	150mm

### Color

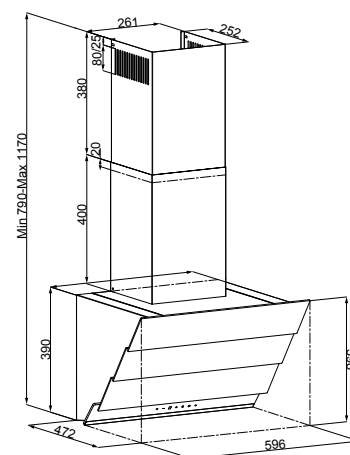

## 3480

### Technical Data

Category	Wall Type Hoods
Size	60cm
Duct Out Version	Intern (Duct Out / Recirculation)
Finish	Inox + Tempered Glass

### Performance Data

Max Flow Rate:	233m <sup>3</sup> /h
Max Noise Level:	55 dB(A)
Total Absorption:	128W
Filter	Aluminium Cassette Filter + Optional Carbon Filter
Control	3S Mechanical Push Button
Lighting	2x1,5W Power LED
Duct Size	120mm

### Color

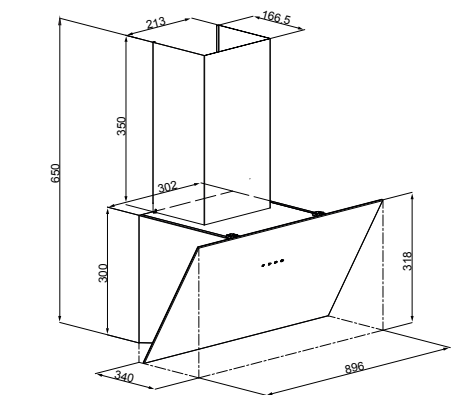

# WALL-MOUNTED HOODS



A



3457

## Technical Data

Category	Wall Type Hoods
Size	60 - 80 - 90cm
Duct Out Version	Intern (Duct Out / Recirculation)
Finish	Inox + Tempered Glass

## Performance Data

Max Flow Rate:	648 m <sup>3</sup> /h
Max Noise Level:	63 dB(A)
Total Absorption:	216W
Filter	Aluminium Casette Filter + Optional Carbon Filter
Control	2S+1B Touch Control
Lighting	2x3W LED
Duct Size	150mm

## Color



Black

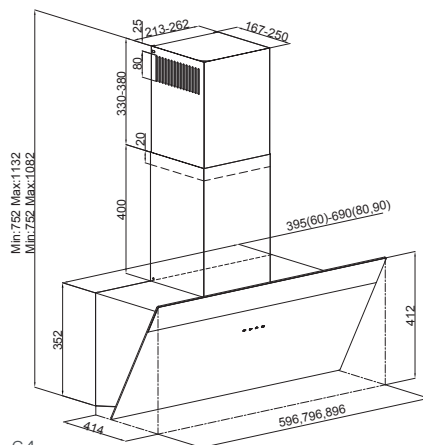

64



A



3455

## Technical Data

Category	Wall Type Hoods
Size	60 - 80 - 90cm
Duct Out Version	Intern (Duct Out / Recirculation)
Finish	Inox + Tempered Glass

## Performance Data

Max Flow Rate:	631 m <sup>3</sup> /h
Max Noise Level:	63 dB(A)
Total Absorption:	216W
Filter	Aluminium Casette Filter + Optional Carbon Filter
Control	2S+1B Touch Control
Lighting	2x3W LED
Duct Size	150mm

## Color



Black

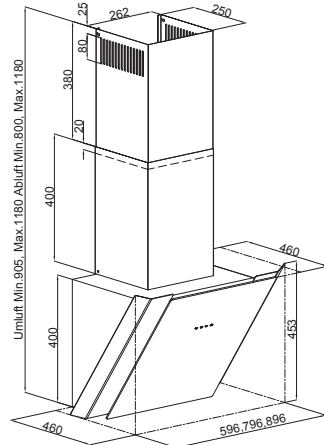

A



3454

## Technical Data

Category	Wall Type Hoods
Size	60 - 80cm
Duct Out Version	Intern (Duct Out / Recirculation)
Finish	Inox

## Performance Data

Max Flow Rate:	647 m <sup>3</sup> /h
Max Noise Level:	65 dB(A)
Total Absorption:	216W
Filter	Aluminium Casette Filter + Optional Carbon Filter
Control	3S Touch Control
Lighting	2x3W LED
Duct Size	150mm

## Color



Black

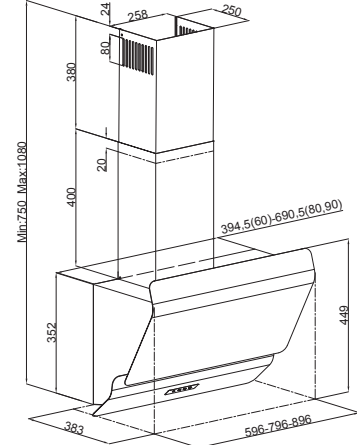

A



3450

## Technical Data

Category	Wall Type Hoods
Size	60 - 90cm
Duct Out Version	Intern (Duct Out / Recirculation)
Finish	Inox + Tempered Glass

## Performance Data

Max Flow Rate:	628 m <sup>3</sup> /h
Max Noise Level:	65 dB(A)
Total Absorption:	216W
Filter	Aluminium Casette Filter + Optional Carbon Filter
Control	3S Touch Control
Lighting	2x3W LED
Duct Size	150mm

## Color



Black White

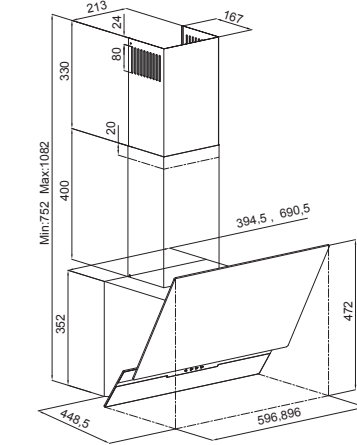

A

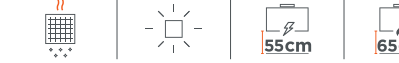

3444

## Technical Data

Category	Wall Type Hoods
Size	60 - 90cm
Duct Out Version	Intern (Duct Out / Recirculation)
Finish	Inox + Tempered Glass

## Performance Data

Max Flow Rate:	660 m <sup>3</sup> /h
Max Noise Level:	64 dB(A)
Total Absorption:	216W
Filter	Aluminium Casette Filter + Optional Carbon Filter
Control	2S+1B Touch Control
Lighting	2x3W LED
Duct Size	150mm

## Color



Black White

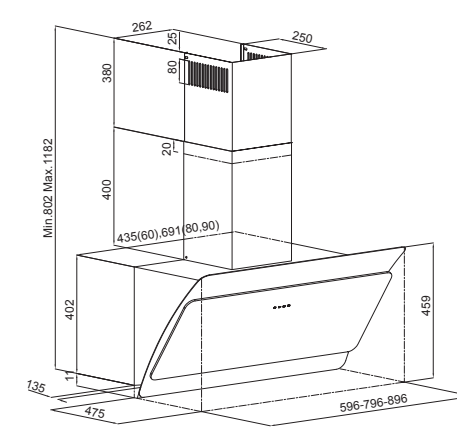

A+



3429

## Technical Data

Category	Wall Type Hoods
Size	60 - 80 - 90cm
Duct Out Version	Intern (Duct Out / Recirculation)
Finish	Inox + Tempered Glass

## Performance Data

Max Flow Rate:	757 m <sup>3</sup> /h
Max Noise Level:	65 dB(A)
Total Absorption:	281W
Filter	Aluminium Casette Filter + Optional Carbon Filter
Control	2S+1B Touch Control
Lighting	2x3W LED
Duct Size	150mm

## Color

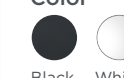

Black White

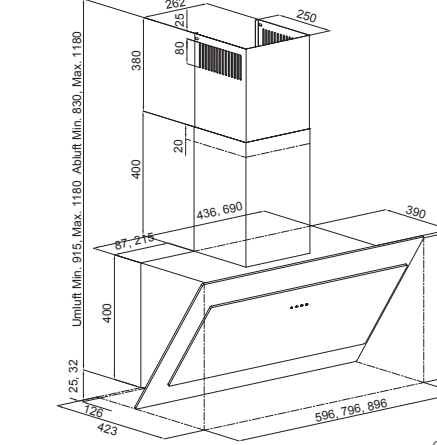

65

# WALL-MOUNTED HOODS



A



3424

## Technical Data

Category	Wall Type Hoods
Size	60 - 80 - 90cm
Duct Out Version	Intern (Duct Out / Recirculation)
Finish	Tempered Glass

## Performance Data

Max Flow Rate:	634 m <sup>3</sup> /h
Max Noise Level:	66 dB(A)
Total Absorption:	216W
Filter	Aluminium Casette Filter + Optional Carbon Filter
Control	3S Touch Control
Lighting	2x3W LED
Duct Size	150mm

## Color



Black White

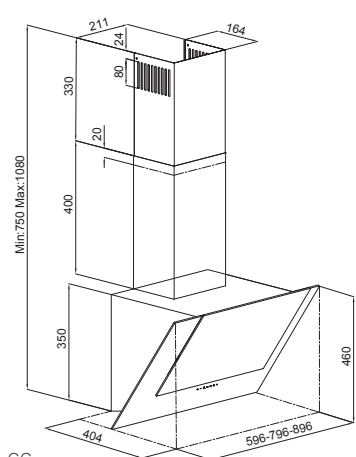

66



A



3423

## Technical Data

Category	Wall Type Hoods
Size	60 - 80 - 90cm
Duct Out Version	Intern (Duct Out / Recirculation)
Finish	Tempered Glass

## Performance Data

Max Flow Rate:	649 m <sup>3</sup> /h
Max Noise Level:	68 dB(A)
Total Absorption:	216W
Filter	Aluminium Casette Filter + Optional Carbon Filter
Control	3S Touch Control
Lighting	2x3W LED
Duct Size	150mm

## Color



Black White

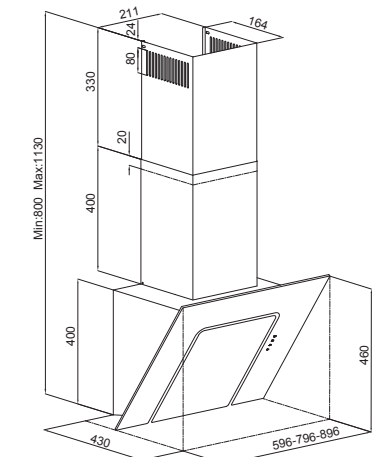

A



3422

## Technical Data

Category	Wall Type Hoods
Size	60 - 80 - 90cm
Duct Out Version	Intern (Duct Out / Recirculation)
Finish	Tempered Glass

## Performance Data

Max Flow Rate:	624 m <sup>3</sup> /h
Max Noise Level:	67 dB(A)
Total Absorption:	216W
Filter	Aluminium Casette Filter + Optional Carbon Filter
Control	3S Touch Control
Lighting	2x3W LED
Duct Size	150mm

## Color



Black White

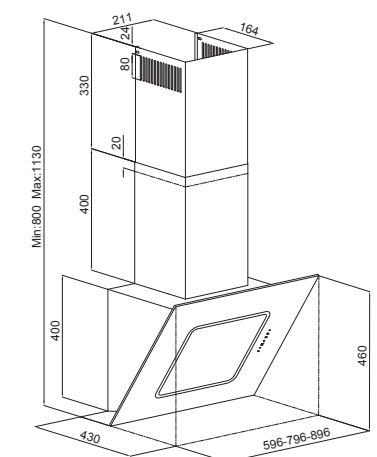

A



3420

## Technical Data

Category	Wall Type Hoods
Size	50 - 60 - 80 - 90cm
Duct Out Version	Intern (Duct Out / Recirculation)
Finish	Tempered Glass

## Performance Data

Max Flow Rate:	621 m <sup>3</sup> /h
Max Noise Level:	64 dB(A)
Total Absorption:	216W
Filter	Aluminium Casette Filter + Optional Carbon Filter
Control	3S Touch Control
Lighting	2x3W LED
Duct Size	150mm

## Color



Black White

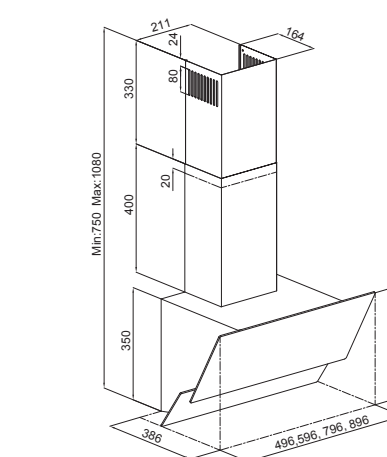

B | hi



3370

## Technical Data

Category	Wall Type Hoods
Size	60 - 80 - 90cm
Duct Out Version	Intern (Duct Out / Recirculation)
Finish	Tempered Glass

## Performance Data

Max Flow Rate:	679 m <sup>3</sup> /h
Max Noise Level:	62 dB(A)
Total Absorption:	282W
Filter	Aluminium Casette Filter + Optional Carbon Filter
Control	3S+1B Touch Control
Lighting	6W Power LED
Duct Size	150mm

## Color



Black White

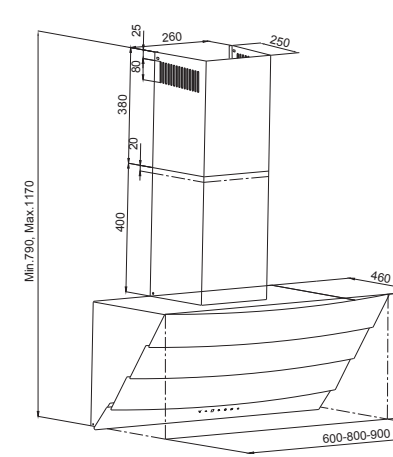

A



3374

## Technical Data

Category	Wall Type Hoods
Size	60 - 80 - 90cm
Duct Out Version	Intern (Duct Out / Recirculation)
Finish	Inox + Tempered Glass

## Performance Data

Max Flow Rate:	614 m <sup>3</sup> /h
Max Noise Level:	65 dB(A)
Total Absorption:	216W
Filter	Aluminium Casette Filter + Optional Carbon Filter
Control	3S Soft Touch with Display
Lighting	2x3W LED
Duct Size	150mm

## Color



Black White

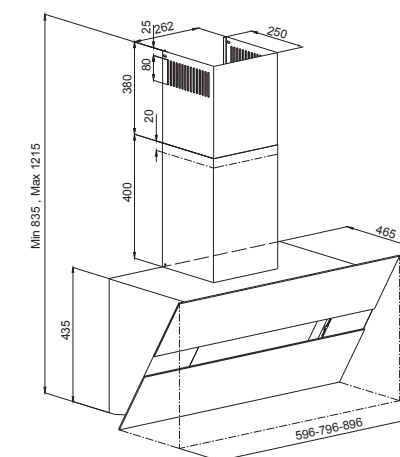

67



# WALL-MOUNTED HOODS



3330

### Technical Data

Category	Wall Type Hoods
Size	60 - 80 - 90cm
Duct Out Version	Intern (Duct Out / Recirculation)
Finish	Inox + Tempered Glass

### Performance Data

Max Flow Rate:	762 m <sup>3</sup> /h
Max Noise Level:	65 dB(A)
Total Absorption:	282W
Filter	Aluminium Cassette Filter + Optional Carbon Filter
Control	3S+1B Soft Touch with Display
Lighting	6W Power LED
Duct Size	150mm



### Color

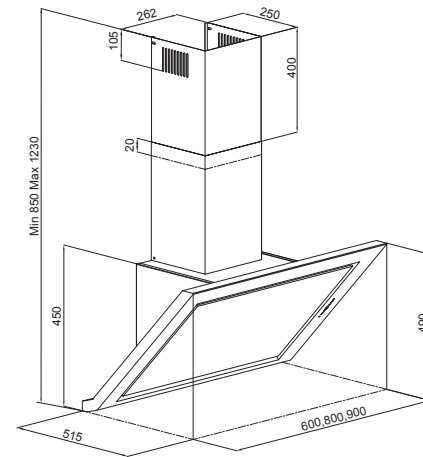

3283

### Technical Data

Category	Wall Type Hoods
Size	60 - 90cm
Duct Out Version	Intern (Duct Out / Recirculation)
Finish	Inox + Tempered Glass

### Performance Data

Max Flow Rate:	649m <sup>3</sup> /h
Max Noise Level:	67 dB(A)
Total Absorption:	216W
Filter	Aluminium Cassette Filter + Optional Carbon Filter
Control	3S Mechanical Push Button
Lighting	2x3W LED
Duct Size	150mm



### Color

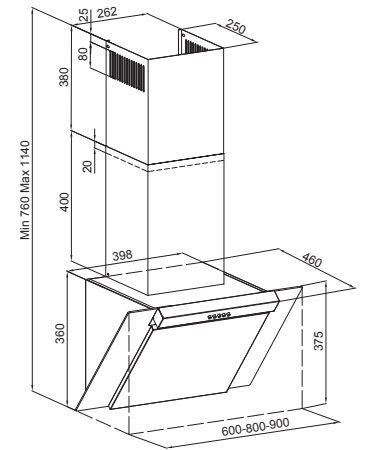

3265

### Technical Data

Category	Wall Type Hoods
Size	60 - 80 - 90 - 120cm
Duct Out Version	Intern (Duct Out / Recirculation)
Finish	Tempered Glass

### Performance Data

Max Flow Rate:	840m <sup>3</sup> /h
Max Noise Level:	56 dB(A)
Total Absorption:	169W
Filter	Aluminium Cassette Filter + Optional Carbon Filter
Control	3S+1B Touch Control
Lighting	9W Power LED
Duct Size	150mm



### Color

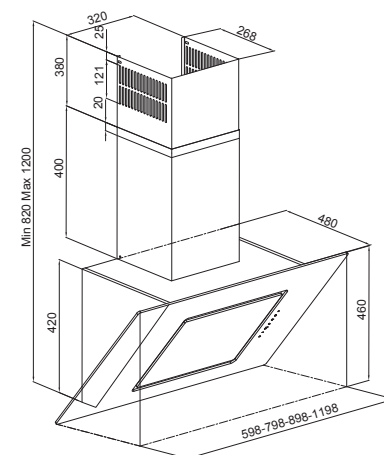

3180

### Technical Data

Category	Wall Type Hoods
Size	100cm
Duct Out Version	Intern (Duct Out / Recirculation)
Finish	Inox

### Performance Data

Max Flow Rate:	783m <sup>3</sup> /h
Max Noise Level:	66 dB(A)
Total Absorption:	284W
Filter	Aluminium Cassette Filter + Optional Carbon Filter
Control	3S+1B Soft Touch with Display
Lighting	3x3W LED
Duct Size	150mm



### Color

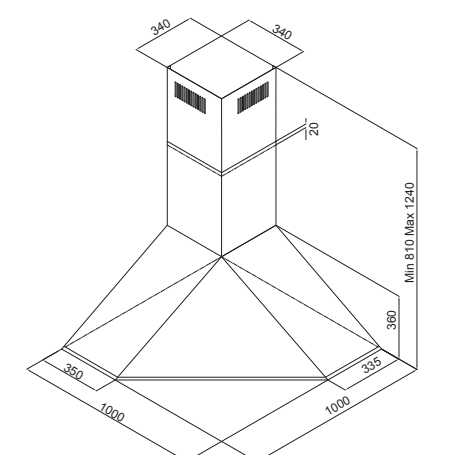

# WALL-MOUNTED HOODS



## 3122

### Technical Data

Category	Wall Type Hoods
Size	60 - 80 - 90cm
Duct Out Version	Intern (Duct Out / Recirculation)
Finish	Inox + Tempered Glass

### Performance Data

Max Flow Rate:	718m <sup>3</sup> /h
Max Noise Level:	65 dB(A)
Total Absorption:	281W
Filter	Aluminium Cassette Filter + Optional Carbon Filter
Control	3S+1B Soft Touch with Display
Lighting	2x1,5W G4 LED
Duct Size	150mm

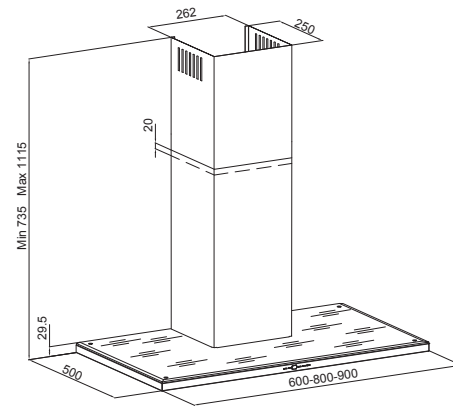
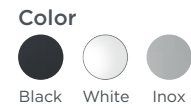

## 3120

### Technical Data

Category	Wall Type Hoods
Size	60 - 90cm
Duct Out Version	Intern (Duct Out / Recirculation)
Finish	Inox

### Performance Data

Max Flow Rate:	744m <sup>3</sup> /h
Max Noise Level:	67 dB(A)
Total Absorption:	281W
Filter	Aluminium Cassette Filter + Optional Carbon Filter
Control	3S+1B Soft Touch with Display
Lighting	2x3W LED
Duct Size	150mm

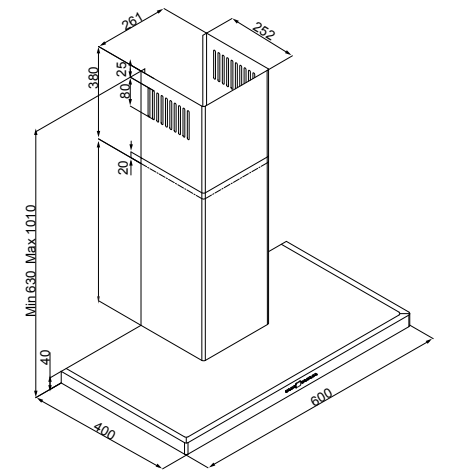
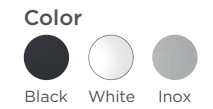

## 3155 LX

### Technical Data

Category	Wall Type Hoods
Size	60 - 90cm
Duct Out Version	Intern (Duct Out / Recirculation)
Finish	Inox + Tempered Glass

### Performance Data

Max Flow Rate:	621m <sup>3</sup> /h
Max Noise Level:	70 dB(A)
Total Absorption:	216W
Filter	Aluminium Cassette Filter + Optional Carbon Filter
Control	3S Touch Control
Lighting	2x3W LED
Duct Size	150mm

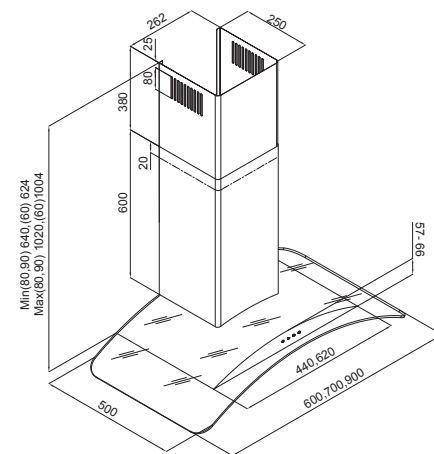
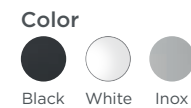

## 2242

### Technical Data

Category	Wall Type Hoods
Size	60 - 90cm
Duct Out Version	Intern (Duct Out / Recirculation)
Finish	Inox

### Performance Data

Max Flow Rate:	632m <sup>3</sup> /h
Max Noise Level:	67 dB(A)
Total Absorption:	216W
Filter	Aluminium Cassette Filter + Optional Carbon Filter
Control	3S Mechanical Push Button
Lighting	1x3W Buji LED
Duct Size	150mm

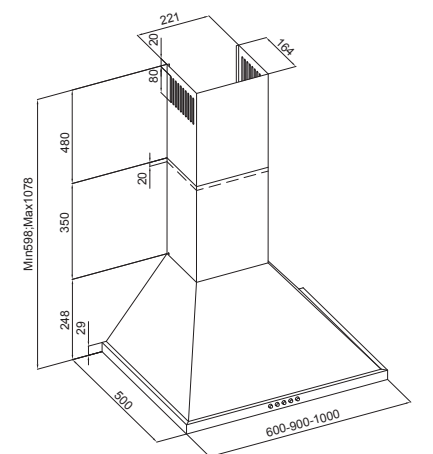
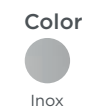

# WALL-MOUNTED HOODS



D



2153

## Technical Data

Category	Wall Type Hoods
Size	60cm
Duct Out Version	Intern (Duct Out / Recirculation)
Finish	Inox

## Performance Data

Max Flow Rate:	253m <sup>3</sup> /h
Max Noise Level:	61 dB(A)
Total Absorption:	128W
Filter	Aluminium Casette Filter + Optional Carbon Filter
Control	3S Mechanical Push Button
Lighting	1x3W Bulb LED
Duct Size	120mm

## Color

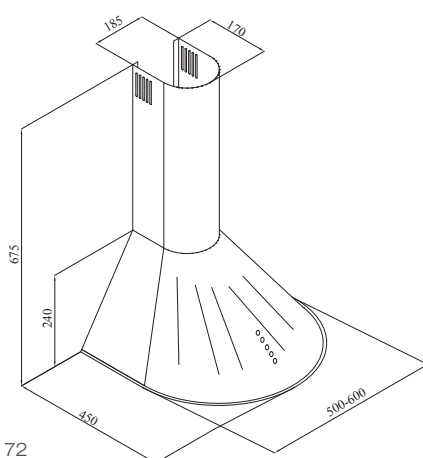

D



2240

## Technical Data

Category	Wall Type Hoods
Size	60cm
Duct Out Version	Intern (Duct Out / Recirculation)
Finish	Inox

## Performance Data

Max Flow Rate:	291m <sup>3</sup> /h
Max Noise Level:	63 dB(A)
Total Absorption:	131W
Filter	Aluminium Casette Filter + Optional Carbon Filter
Control	3S Mechanical Push Button
Lighting	2x3W Bulb LED
Duct Size	120mm

## Color

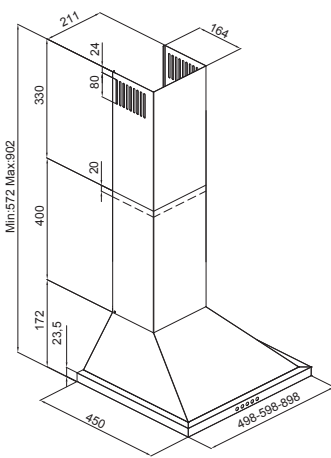

A



2180

## Technical Data

Category	Wall Type Hoods
Size	60 - 90cm
Duct Out Version	Intern (Duct Out / Recirculation)
Finish	Inox

## Performance Data

Max Flow Rate:	636m <sup>3</sup> /h
Max Noise Level:	70 dB(A)
Total Absorption:	310W
Filter	Aluminium Casette Filter + Optional Carbon Filter
Control	3S Soft Touch with Display
Lighting	2x50W Halojen Lamba
Duct Size	150mm

## Color

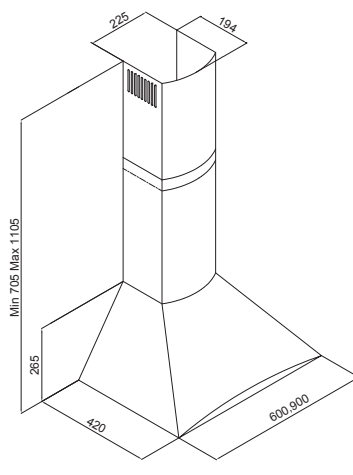

A



3110

## Technical Data

Category	Wall Type Hoods
Size	60 - 90cm
Duct Out Version	Intern (Duct Out / Recirculation)
Finish	Inox + Tempered Glass

## Performance Data

Max Flow Rate:	637m <sup>3</sup> /h
Max Noise Level:	65 dB(A)
Total Absorption:	216W
Filter	Aluminium Casette Filter + Optional Carbon Filter
Control	3S Soft Touch with Display
Lighting	2x3W LED
Duct Size	150mm

## Color

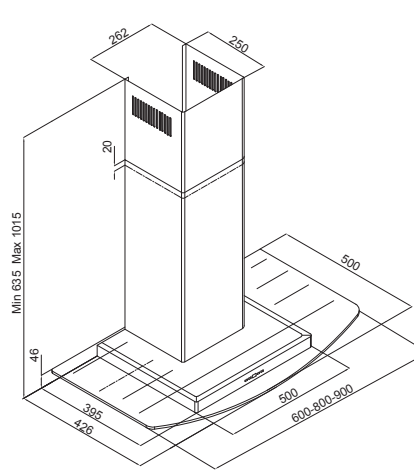

A



3170

## Technical Data

Category	Wall Type Hoods
Size	60 - 80 - 90 - 120cm
Duct Out Version	Intern (Duct Out / Recirculation)
Finish	Inox

## Performance Data

Max Flow Rate:	562m <sup>3</sup> /h
Max Noise Level:	67 dB(A)
Total Absorption:	216W
Filter	Aluminium Casette Filter + Optional Carbon Filter
Control	3S Soft Touch with Display / Mechanical Push Button
Lighting	2x3W LED
Duct Size	150mm

## Color

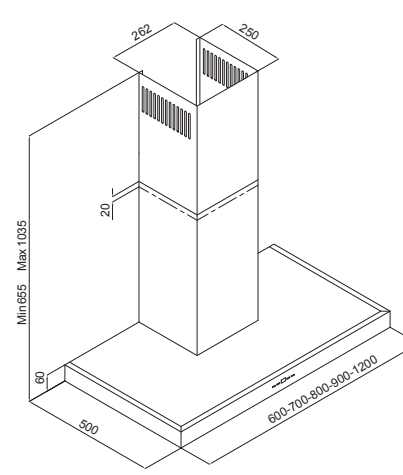

A



3173

## Technical Data

Category	Wall Type Hoods
Size	60 - 80 - 90 - 120cm
Duct Out Version	Intern (Duct Out / Recirculation)
Finish	Inox + Tempered Glass

## Performance Data

Max Flow Rate:	710m <sup>3</sup> /h
Max Noise Level:	65 dB(A)
Total Absorption:	281W
Filter	Aluminium Casette Filter + Optional Carbon Filter
Control	2S+1B Touch Control
Lighting	2x1,5W G4 LED
Duct Size	150mm

## Color

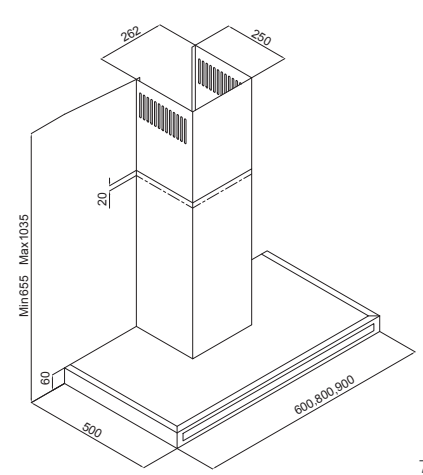

# WALL-MOUNTED HOODS



## 3182 MIA

### Technical Data

Category	Wall Type Hoods
Size	60-80-90cm
Duct Out Version	Intern (Duct Out / Recirculation)
Finish	Inox + Tempered Glass

### Performance Data

Max Flow Rate:	648m <sup>3</sup> /h
Max Noise Level:	66 dB(A)
Total Absorption:	277W
Filter	Aluminium Casette Filter + Optional Carbon Filter
Control	Touch Control
Lighting	2W LED
Duct Size	150mm

### Color



Black White Inox

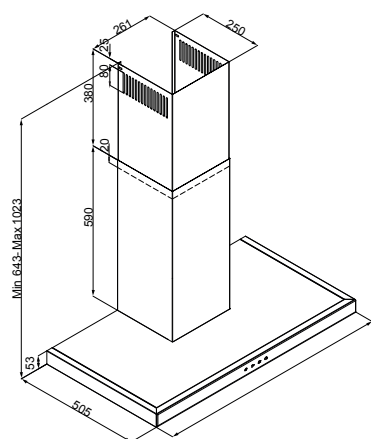

## 3182 MILA

### Technical Data

Category	Wall Type Hoods
Size	60-80-90cm
Duct Out Version	Intern (Duct Out / Recirculation)
Finish	Inox + Tempered Glass

### Performance Data

Max Flow Rate:	425m <sup>3</sup> /h
Max Noise Level:	63 dB(A)
Total Absorption:	277W
Filter	Aluminium Casette Filter + Optional Carbon Filter
Control	Touch Control
Lighting	2W ECO LED
Duct Size	150mm

### Color



Black Inox

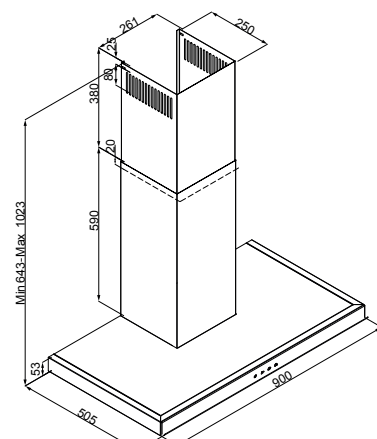

# BUILT-IN HOODS

With a range of products for every kitchen type, Silverline can meet customer requirements with its cabinet solutions as well.

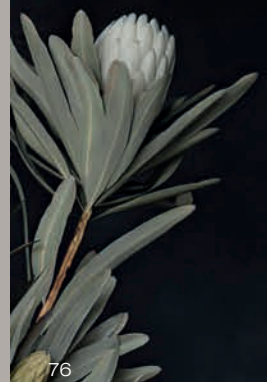





## Vapor Sensor

The sensor increases or decreases the suction speed of the product by detecting the density of the food vapor.



## Easily Emptied Water Collector

Accumulated water can be easily drained with a small bowl.

## Anti-Condensation

Inside Pro solves the condensation problem during the cooking experience with induction hobs.

With the anti-condensation key, the heater is activated and condensation is prevented.

The resistors prevent condensation on the surface by reducing the temperature difference between vapor and metallic components.



## Drop Control Filter And Water Tank

The filter keeps the condensation formed during cooking and the condensed water flows into the water tank thanks to the filter angle.

Even if the product is exposed to intense steam, water does not drip from the filter.





## BUILT-IN HOODS



### 3129 INSIDE PRO

### DROP CONTROL



#### Technical Data

Category	Built-in Hood
Size	60-90-120 cm
Duct Out Veraiion	Intern (Duct Out/Recirculation)
Finish	Inox + Tempered Glass

#### Performance Data

Max Flow Rate	648 m <sup>3</sup> /h (60cm) / 635 m <sup>3</sup> /h (90&120cm)
Max Noise Level	64 dB(A)
Total Absorbation	125 W
Filter	Stainless Steel Cassette Filter + Optional Carbon Filter
Control	3S Touch Control
Lighting	1x8 W LED Stripe
Duct Size	150 mm

#### Color



Black

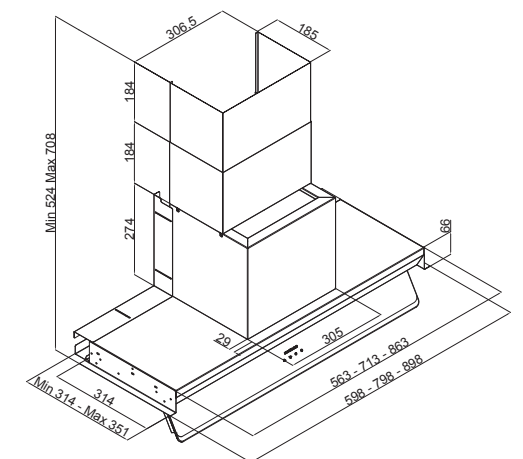

# BUILT-IN HOODS



## 3129 INSIDE 4 DROP CONTROL

### Technical Data

Category	Suspended Hood
Size	60-90-120 cm
Duct Out Version	Intern (Duct Out/Recirculation)
Finish	Inox + Tempered Glass

### Performance Data

Max Flow Rate	628 m <sup>3</sup> /h
Max Noise Level	64 dB(A)
Total Absorption	220 W
Filter	Stainless Steel Cassette Filter + Optional Carbon Filter
Control	3S Touch Control
Lighting	1x10 W LED Stripe
Duct Size	150 mm

**Color**  
 Inox  
 Black

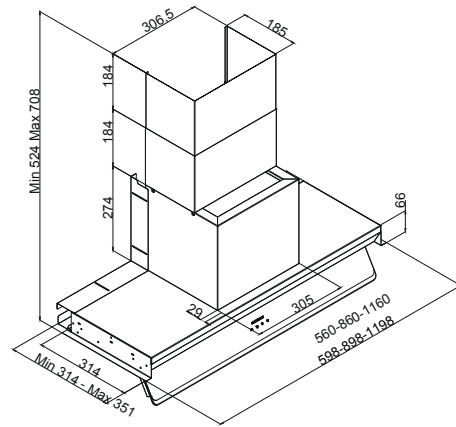

## 3129 INSIDE 3S DROP CONTROL

### Technical Data

Category	Built-in Hoods
Size	60 - 90 - 120cm
Duct Out Version	Intern (Duct Out / Recirculation)
Finish	Inox + Tempered Glass

### Performance Data

Max Flow Rate:	648 m <sup>3</sup> /h
Max Noise Level:	64 dB(A)
Total Absorption:	213W
Filter	Stainless Steel Cassette Filter + Optional Carbon Filter
Control	3S Touch Control
Lighting	2x1,5W LED
Duct Size	150mm

**Color**  
 Inox  
 Black

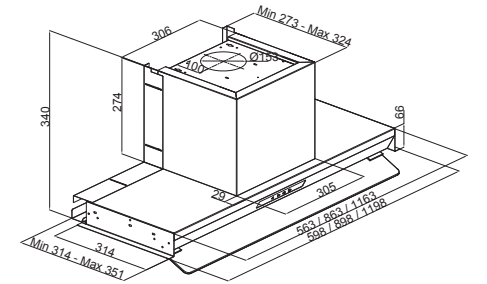

## 3129 INSIDE 3 DROP CONTROL

### Technical Data

Category	Built-in Hoods
Size	60 - 90 - 120cm
Duct Out Version	Intern (Duct Out / Recirculation)
Finish	Inox + Tempered Glass

### Performance Data

Max Flow Rate:	628 m <sup>3</sup> /h
Max Noise Level:	64 dB(A)
Total Absorption:	220W
Filter	Stainless Steel Cassette Filter + Optional Carbon Filter
Control	3S Touch Control
Lighting	1x10W LED Stripe
Duct Size	150mm

**Color**  
 Inox  
 Black

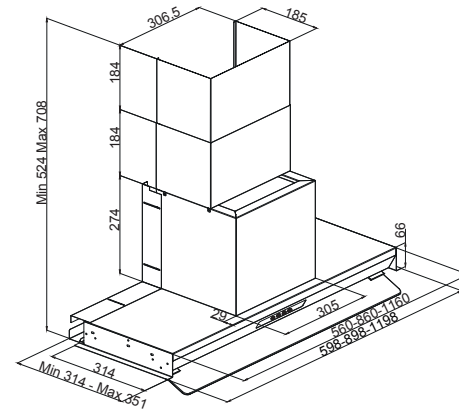

## 3129 INSIDE 1

### Technical Data

Category	Built-in Hoods
Size	60 - 90 - 120cm
Duct Out Version	Intern (Duct Out / Recirculation)
Finish	Inox + Tempered Glass

### Performance Data

Max Flow Rate:	465 m <sup>3</sup> /h
Max Noise Level:	64 dB(A)
Total Absorption:	128W
Filter	Aluminium Cassette Filter + Optional Carbon Filter
Control	3S Slider Control
Lighting	2x1,5W G4 LED
Duct Size	150mm

**Color**  
 Inox  
 Black

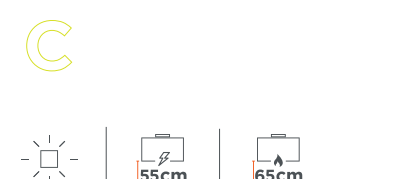
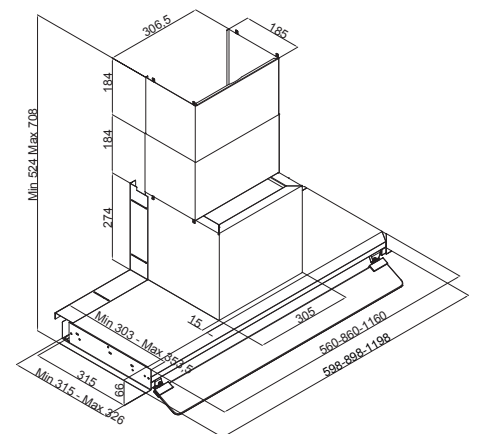

**Color**  
 Inox  
 Black

# BUILT-IN HOODS



A



## 1182 LIGHTFACE

### Technical Data

Category	Built-in Hoods
Size	60cm
Duct Out Version	Intern (Duct Out / Recirculation)
Finish	Inox + Tempered Glass

### Performance Data

Max Flow Rate:	714 m <sup>3</sup> /h
Max Noise Level:	69 dB(A)
Total Absorption:	287W
Filter	Stainless Steel Casette Filter + Optional Carbon Filter
Control	2S+1B Touch Control
Lighting	1x12W LED
Duct Size	150mm

### Color



Black White

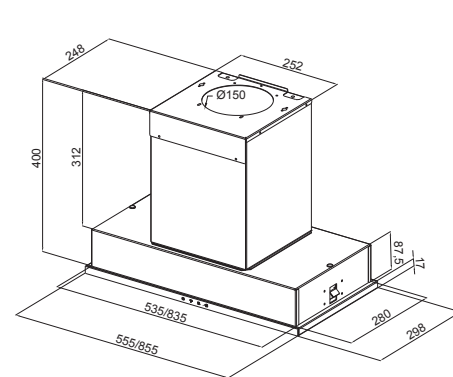

A



## 1181 ULIGHT

### Technical Data

Category	Built-in Hoods
Size	60 - 90cm
Duct Out Version	Intern (Duct Out / Recirculation)
Finish	Inox + Tempered Glass

### Performance Data

Max Flow Rate:	703 m <sup>3</sup> /h
Max Noise Level:	66 dB(A)
Total Absorption:	284W
Filter	Stainless Steel Casette Filter + Optional Carbon Filter
Control	2S+1B Touch Control
Lighting	1x9W LED Stripe
Duct Size	150mm

### Color



Black White

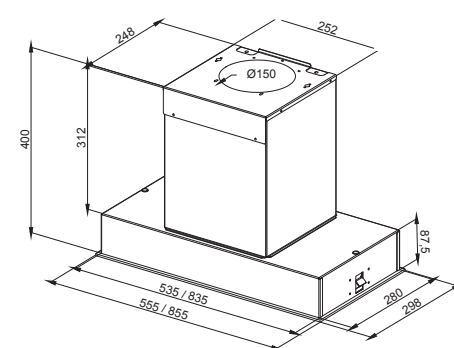

A | hi



## 1176

### Technical Data

Category	Built-in Hoods
Size	60 - 70 - 90cm
Duct Out Version	Intern (Duct Out / Recirculation)
Finish	Tempered Glass

### Performance Data

Max Flow Rate:	708 m <sup>3</sup> /h
Max Noise Level:	66 dB(A)
Total Absorption:	281W
Filter	Aluminium Casette Filter + Optional Carbon Filter
Control	3S+1B Soft Touch with Display
Lighting	6W Power LED
Duct Size	150mm

### Color



Black White

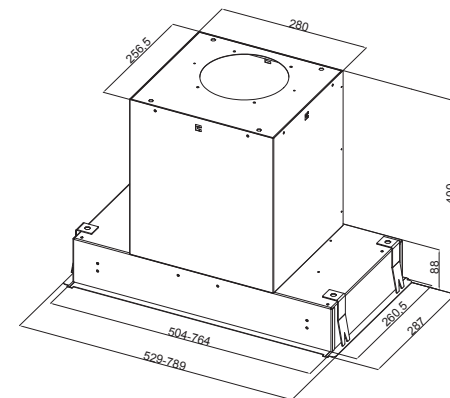

D



## 1171

### Technical Data

Category	Built-in Hoods
Size	52cm
Duct Out Version	Intern (Duct Out / Recirculation)
Finish	Inox

### Performance Data

Max Flow Rate:	415 m <sup>3</sup> /h
Max Noise Level:	62 dB(A)
Total Absorption:	191W
Filter	Aluminium Casette Filter + Optional Carbon Filter
Control	3S Mechanical Slider
Lighting	2x3W LED
Duct Size	120mm

### Color



Black White Inox

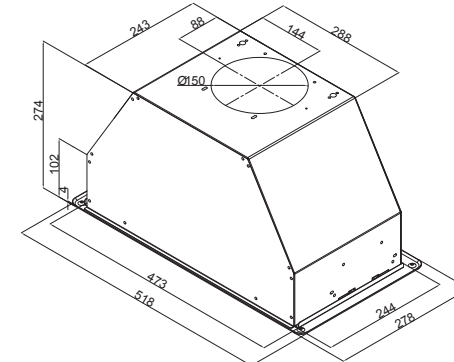

A | hi



## 1175

### Technical Data

Category	Built-in Hoods
Size	60 - 90cm
Duct Out Version	Intern (Duct Out / Recirculation)
Finish	Inox + Tempered Glass

### Performance Data

Max Flow Rate:	520 m <sup>3</sup> /h
Max Noise Level:	64 dB(A)
Total Absorption:	199W
Filter	Stainless Steel Casette Filter + Optional Carbon Filter
Control	5S Soft Touch with Display
Lighting	4x1,1W Power LED
Duct Size	150mm

### Color



Black White

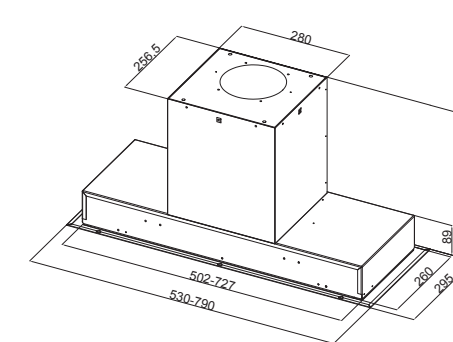

C



## 1162

### Technical Data

Category	Built-in Hoods
Size	60cm
Duct Out Version	Intern (Duct Out / Recirculation)
Finish	Inox + Tempered Glass

### Performance Data

Max Flow Rate:	530 m <sup>3</sup> /h
Max Noise Level:	65 dB(A)
Total Absorption:	138W
Filter	Aluminium Casette Filter + Optional Carbon Filter
Control	3S Touch Control
Lighting	2x1,5W G4 LED
Duct Size	150mm

### Color

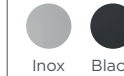

Inox Black

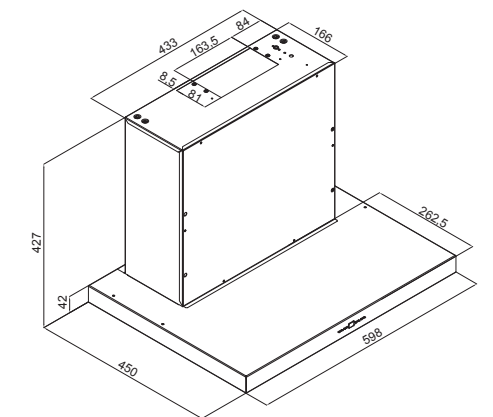

# BUILT-IN HOODS



A

D

A

D

D

D



## 1144

**Technical Data**

Category	Built-in Hoods
Size	60-90cm
Duct Out Version	Intern (Duct Out / Recirculation)
Finish	Inox + Tempered Glass

**Performance Data**

Max Flow Rate:	648 m <sup>3</sup> /h
Max Noise Level:	67 dB(A)
Total Absorption:	216W
Filter	Aluminium Cassette Filter + Charcoal Carbon Filter
Control	3S Touch Control
Lighting	2x3W LED
Duct Size	150mm

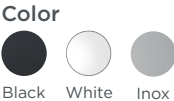

## 1350

**Technical Data**

Category	Built-in Hoods
Size	60cm
Duct Out Version	Intern (Duct Out / Recirculation)
Finish	Inox + Tempered Glass

**Performance Data**

Max Flow Rate:	483 m <sup>3</sup> /h
Max Noise Level:	68 dB(A)
Total Absorption:	254W
Filter	Aluminium Cassette Filter + Charcoal Carbon Filter
Control	3S Touch Control / Rocker
Lighting	2x3W Halojen LED
Duct Size	120mm

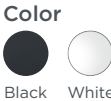

## 1190

**Technical Data**

Category	Built-in Hoods
Size	60 - 90cm
Duct Out Version	Intern (Duct Out / Recirculation)
Finish	Inox

**Performance Data**

Max Flow Rate:	410 m <sup>3</sup> /h
Max Noise Level:	69 dB(A)
Total Absorption:	126W
Filter	Aluminium Cassette Filter + Charcoal Carbon Filter
Control	3S Rocker
Lighting	2x3W LED
Duct Size	120mm

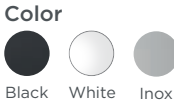

## 1151

**Technical Data**

Category	Built-in Hoods
Size	60cm
Duct Out Version	Intern (Duct Out / Recirculation)
Finish	Inox

**Performance Data**

Max Flow Rate:	483 m <sup>3</sup> /h
Max Noise Level:	68 dB(A)
Total Absorption:	256W
Filter	Aluminium Cassette Filter + Charcoal Carbon Filter
Control	3S Touch Control / Rocker
Lighting	2x3W LED
Duct Size	120mm

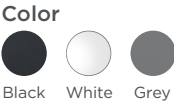

## 1201

**Technical Data**

Category	Built-in Hoods
Size	60cm
Duct Out Version	Intern (Duct Out / Recirculation)
Finish	Inox

**Performance Data**

Max Flow Rate:	483 m <sup>3</sup> /h
Max Noise Level:	68 dB(A)
Total Absorption:	254W
Filter	Aluminium Cassette Filter + Optional Carbon Filter
Control	3S Mechanical Push Button
Lighting	2x2W Bulb LED
Duct Size	120mm



## 1200

**Technical Data**

Category	Built-in Hoods
Size	50-60-90cm
Duct Out Version	Intern (Duct Out / Recirculation)
Finish	Inox

**Performance Data**

Max Flow Rate:	215 m <sup>3</sup> /h
Max Noise Level:	67 dB(A)
Total Absorption:	128W
Filter	Aluminium Cassette Filter + Optional Carbon Filter
Control	3S Mechanical Push Button
Lighting	1x3W Buji LED

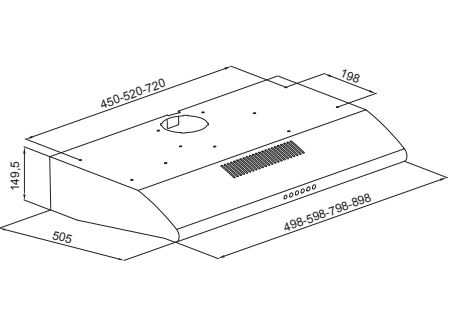
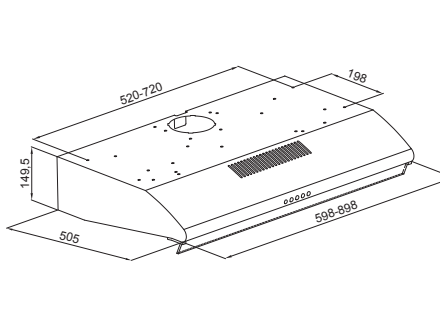
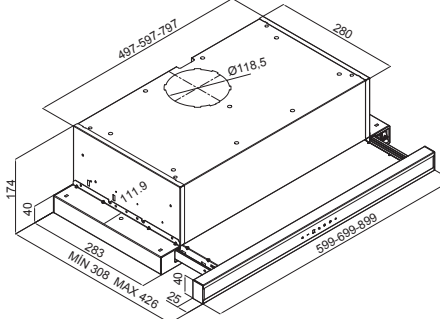
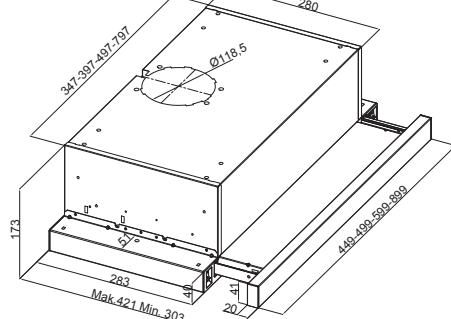
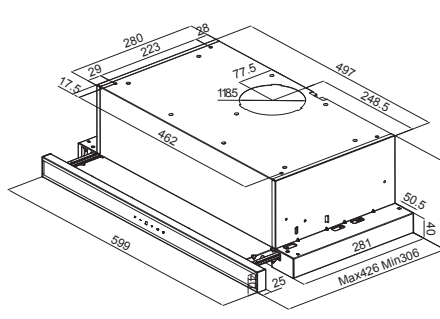
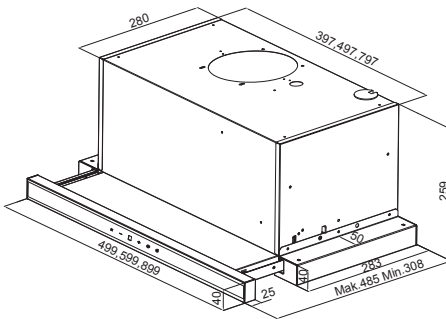
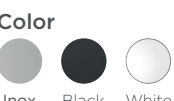



# EXTERNAL MOTORS



## 1240

### Technical Data

Category	Extern Motor
Finish	Inox

### Performance Data

Max Flow Rate:	800 m <sup>3</sup> /h
Total Absorption:	275W
Duct Size	150mm

### Color

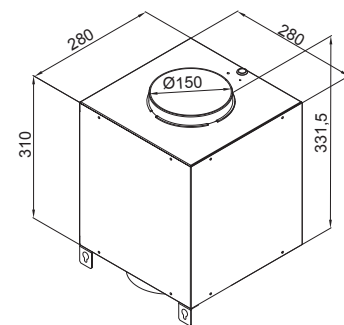
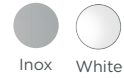

## 1250

### Technical Data

Category	Extern Motor
Finish	Inox

### Performance Data

Max Flow Rate:	1400 m <sup>3</sup> /h
Total Absorption:	550W
Duct Size	200mm

### Color

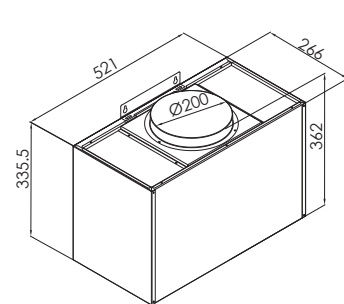

## 1260

### Technical Data

Category	Extern Motor
Finish	Inox

### Performance Data

Max Flow Rate:	1000 m <sup>3</sup> /h
Total Absorption:	280W
Duct Size	150mm

### Color

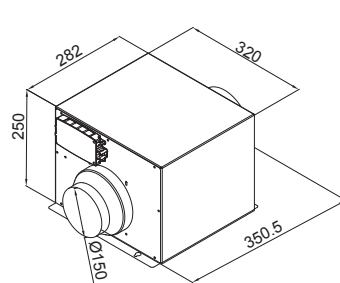

## 1270

### Technical Data

Category	Extern Motor
Finish	Inox

### Performance Data

Max Flow Rate:	950 m <sup>3</sup> /h
Total Absorption:	200W
Duct Size	150mm

### Color

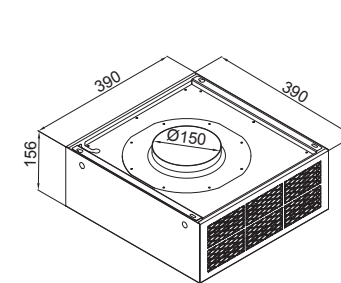

## 1280

### Technical Data

Category	Technology
Finish	Inox

### Performance Data

Duct Size	150mm
-----------	-------

### Color

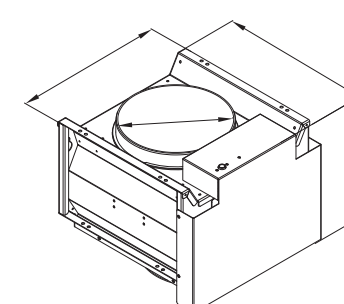

# REMOTE CONTROLS

## CURVED REMOTE CONTROL

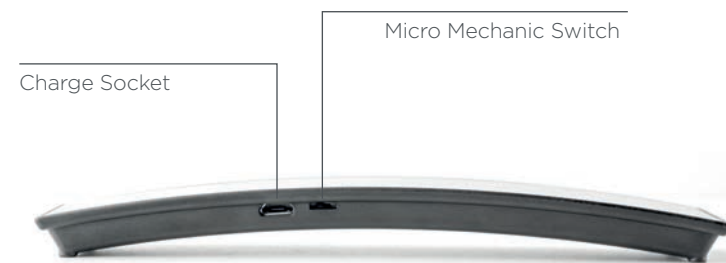
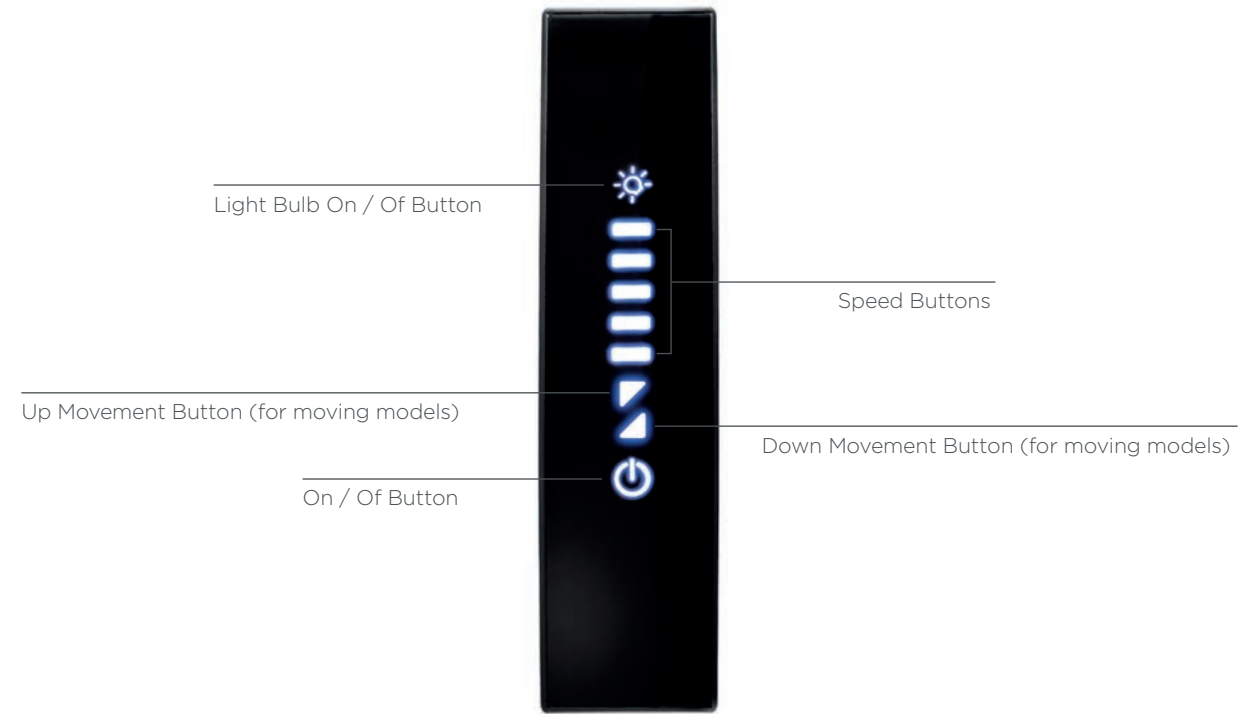

### ERGONOMICS

Curved design which fits ergonomics of hand perfectly.

### USER-FRIENDLY

Control all of the hood features at a touch.

### RECHARGEABLE

Lithium battery, rechargeable by the included micro USB cord.

### MAGNETIC

Magnets placed inside the body allow it to be securely placed on any metal surface.

## STANDARD REMOTE CONTROL

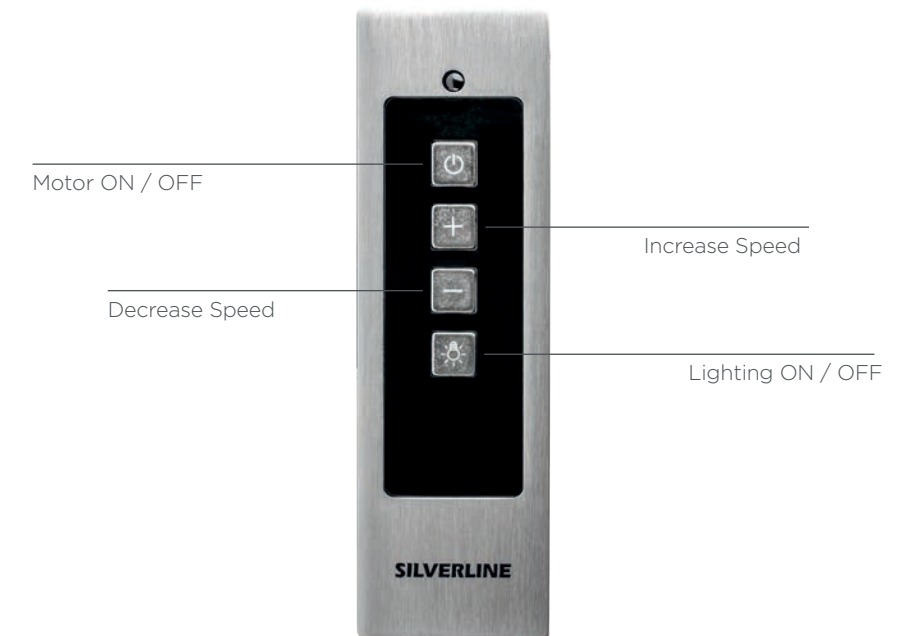



# retroline

indispensable designs that  
combine classic values and  
high technology



# RETRO SERIES



2238

### Technical Data

Category	Retro Hoods
Size	60 - 90cm
Duct Out Version	Intern (Duct Out / Recirculation)
Finish	Inox

### Color

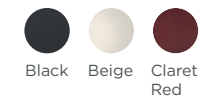

### Performance Data

Max Flow Rate:	636 m <sup>3</sup> /h
Max Noise Level:	67 dB(A)
Total Absorption:	216W
Filter	Aluminium Casette Filter + Optional Carbon Filter
Control	3S Mechanical Push Button
Lighting	2x3W LED
Duct Size	150mm

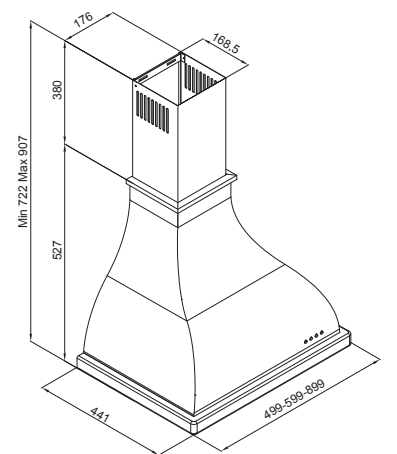

# RETRO SERIES



## RS5336C01

<b>Hob Features</b>	Built-in 70cm Beige
<b>Comfort Features</b>	Cast Iron Pans Supports 4 Gas Burners 1 WOK Auto Ignition Front Mechanical Control
<b>Safety</b>	/
<b>Other Features</b>	Product Dimensions (WxDxH): 680 x 500 x 90mm Cut Out Dimensions (WxDxH): 553 x 473mm 1 x WOK burner: 3300 W 1 x Rapid burner: 3000 W 2 x Semi-rapid burner: 1750 W 1 x Auxiliary burner: 1000 W Maximum Power: 10800 W Gas Type: NG NG/LPG Options

## RS5322C01

<b>Hob Features</b>	Built-in 60cm Beige
<b>Comfort Features</b>	Cast Iron Pans Supports 3 Gas Burners 1 WOK Auto Ignition Front Mechanical Control
<b>Safety</b>	/
<b>Other Features</b>	Product Dimensions (WxDxH): 580 x 500 x 35mm Cut Out Dimensions (WxDxH): 553 x 473mm 1 x WOK burner: 3300 W 1 x Rapid burner: 3000 W 1 x Semi-rapid burner: 1750 W 1 x Auxiliary burner: 1000 W Maximum Power: 9050 W Gas Type: NG NG/LPG Options

## RS5322B01

<b>Hob Features</b>	Built-in 60cm Black
<b>Comfort Features</b>	Cast Iron Pans Supports 3 Gas Burners 1 WOK Auto Ignition Front Mechanical Control
<b>Safety</b>	/
<b>Other Features</b>	Product Dimensions (WxDxH): 580 x 500 x 35mm Cut Out Dimensions (WxDxH): 553 x 473mm 1 x WOK burner: 3300 W 1 x Rapid burner: 3000 W 1 x Semi-rapid burner: 1750 W 1 x Auxiliary burner: 1000 W Maximum Power: 9050 W Gas Type: NG NG/LPG Options

## RS5336B01

<b>Hob Features</b>	Built-in 70cm Black
<b>Comfort Features</b>	Cast Iron Pans Supports 4 Gas Burners 1 WOK Auto Ignition Front Mechanical Control
<b>Safety</b>	/
<b>Other Features</b>	Product Dimensions (WxDxH): 680 x 500 x 90mm Cut Out Dimensions (WxDxH): 553 x 473mm 1 x WOK burner: 3300 W 1 x Rapid burner: 3000 W 2 x Semi-rapid burner: 1750 W 1 x Auxiliary burner: 1000 W Maximum Power: 10800 W Gas Type: NG NG/LPG Options

## RS5322R01

<b>Hob Features</b>	Built-in 60cm Bordeaux
<b>Comfort Features</b>	Cast Iron Pans Supports 3 Gas Burners 1 WOK Auto Ignition Front Mechanical Control
<b>Safety</b>	/
<b>Other Features</b>	Product Dimensions (WxDxH): 580 x 500 x 35mm Cut Out Dimensions (WxDxH): 553 x 473mm 1 x WOK burner: 3300 W 1 x Rapid burner: 3000 W 1 x Semi-rapid burner: 1750 W 1 x Auxiliary burner: 1000 W Maximum Power: 9050 W Gas Type: NG NG/LPG Options

## RS5336R01

<b>Hob Features</b>	Built-in 70cm Bordeaux
<b>Comfort Features</b>	Cast Iron Pans Supports 4 Gas Burners 1 WOK Auto Ignition Front Mechanical Control
<b>Safety</b>	/
<b>Other Features</b>	Product Dimensions (WxDxH): 680 x 500 x 90mm Cut Out Dimensions (WxDxH): 553 x 473mm 1 x WOK burner: 3300 W 1 x Rapid burner: 3000 W 2 x Semi-rapid burner: 1750 W 1 x Auxiliary burner: 1000 W Maximum Power: 10800 W Gas Type: NG NG/LPG Options

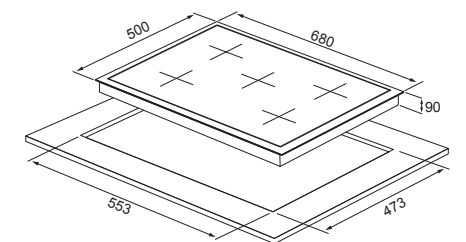
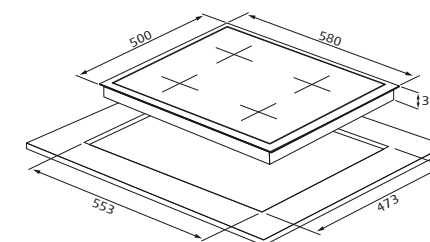
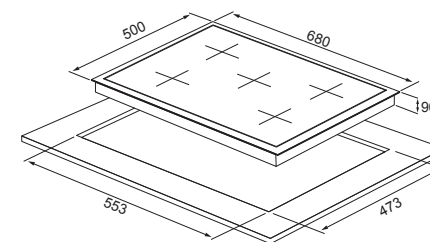
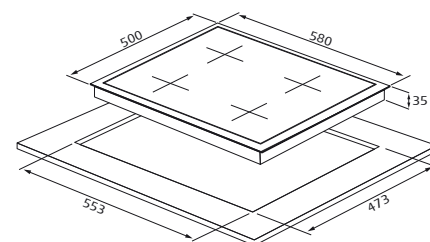
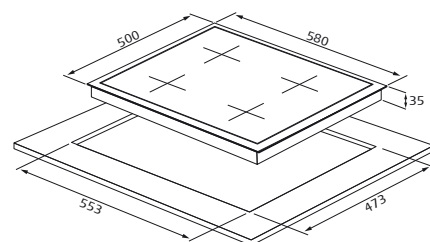
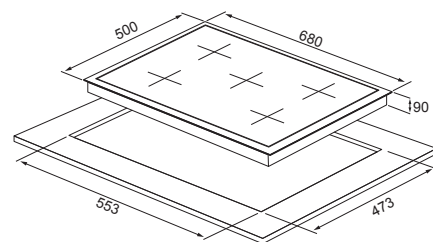

# RETRO SERIES

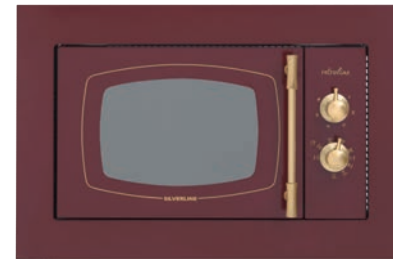

RS6507R01

RS6507C01

RS6507B01

MW9033R02

MW9033C02

MW9033B02



<b>Oven Type</b>	Built-in Electric Oven 72 liter A Energy class
<b>Cooking Functions</b>	8 functions 3D Airmove Rapid pre-heating Maxi grill, thermostat, turbo fan Cooling fan
<b>Cleaning</b>	Self Clean Steam Clean Easy Extract
<b>Comfort</b>	Analog Timer (automatic cooking time end closure) 2 Rustic style knobs Screen child lock Removable side racks Telescopic rail Oven light Double glass door
<b>Accessories</b>	1 chrome grid, 1 deep and 1 standard tray Airfry tray (optional)
<b>Dimensions</b>	595x547x595

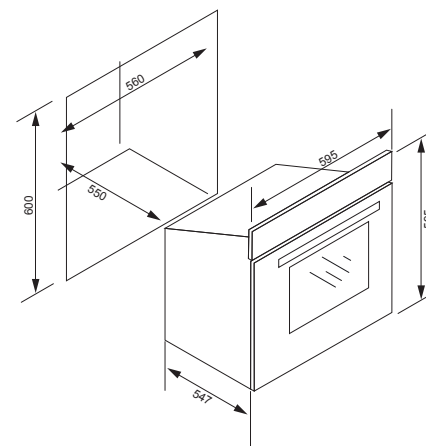
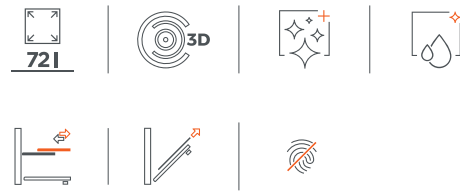

<b>Microwave Type</b>	Built-In Microwave 20 Lt Capacity
<b>Cooking Function</b>	Microwave + Grill cooking
<b>Comfort</b>	3 Combination power settings 30 minutes mechanic timer Cooking end signal Pull handle door, defrost setting
<b>Safety</b>	/
<b>Others</b>	Power output 800w 1100W grill Glass turntable Metal rack Stainless cavity and silver housing

**6** Program | **20** Liter | **5** Level

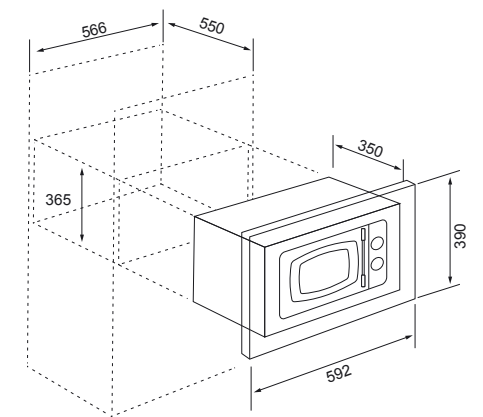

# VINTAGE SERIES



2120

### Technical Data

Category	Retro Hoods
Size	60 - 90cm
Duct Out Version	Intern (Duct Out / Recirculation)
Finish	Inox

### Performance Data

Max Flow Rate:	648 m <sup>3</sup> /h
Max Noise Level:	68 dB(A)
Total Absorption:	216W
Filter	Aluminium Cassette Filter + Optional Carbon Filter
Control	3S Mechanical Push Button
Lighting	2x3W LED
Duct Size	150mm

### Color

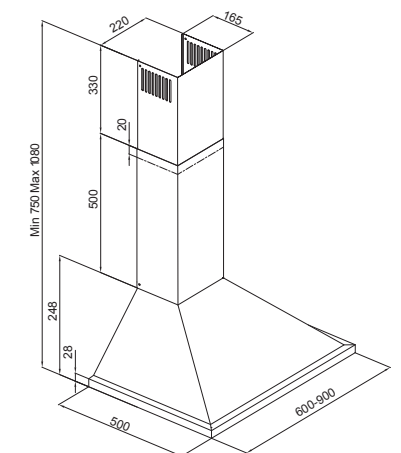
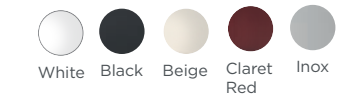

# VINTAGE SERIES



ARO5620B01



ARO5620W01



ARO5620C01



ARF6607B01



ARF6607W01



ARF6607C01



<b>Oven Type</b>	Built-in Electric Oven 72 liter A Energy class
<b>Cooking Functions</b>	6 functions Maxi grill, thermostat, turbo fan Rapid pre-heating Cooling fan
<b>Cleaning</b>	Self clean, steam clean, easy extract
<b>Comfort</b>	Mechanical timer Removable side racks Oven light Triple glass door
<b>Accessories</b>	1 chrome grid, 1 deep, 1 standard tray
<b>Dimensions</b>	595x547x595

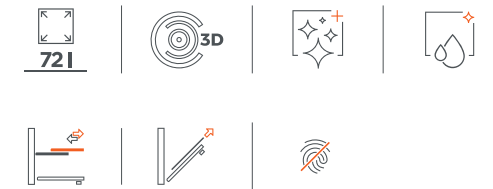

<b>Hob Features</b>	Built-in 60cm Black / White / Beige
<b>Comfort Features</b>	Enamel Pan Supports 4 Gas Burners Auto Ignition Side Mechanical Control
<b>Safety</b>	Gas Cutting Safety
<b>Other Features</b>	Product Dimensions (WxDxH): 680 x 500 x 90mm Cut Out Dimensions (WxDxH): 553 x 473mm 1 x Rapid burner: 3000 W 2 x Semi-rapid burner: 1750 W 1 x Auxiliary burner: 1000 W Maximum Power: 10800 W Gas Type: NG NG/LPG Options

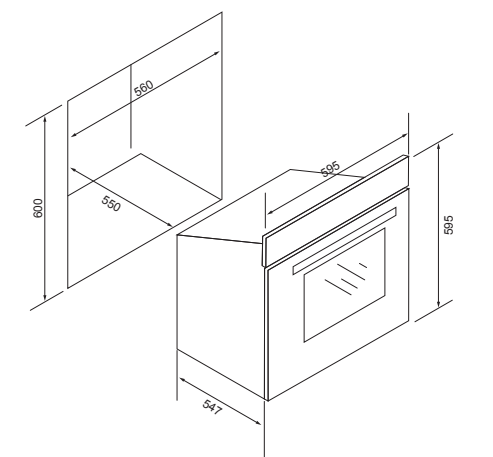
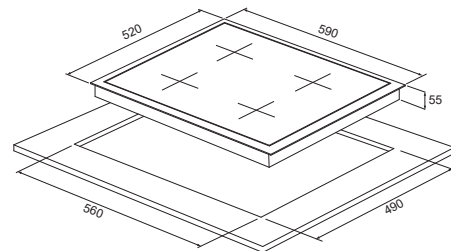



## OVENS

The kind of multi-functionality that adds taste to your meals and makes expert cooks envious at the same time is now integrated with a multi-dimensional understanding of design.



### MEAT PROBE

It gives very accurate cooking results by measuring the internal temperature of the food.



### TELESCOPIC RAIL

Allows you to remove trays easily from the oven. This makes usage of trays more convenient and easy to use.

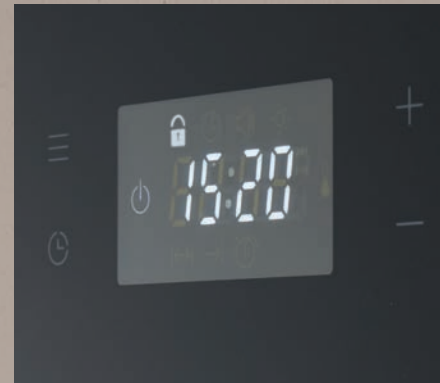

### CHILD SCREEN LOCK

No matter what key your child plays on the screen, the settings of your oven can't be changed.



### COOL DOOR

The reflective glass on the inside of the door significantly reduces the temperature of the outer part of the door at all ovens. So, it provides a safer environment when preparing the delicious meals in the oven.



### 3D AIR FLOW

It provides proper heat distribution for uniform cooking and convenient for cooking up to 3 trays.



### LARGE CAVITY SIZE

It gives flexibility to prepare larger meals with its 72 liter net volume.





## Easy Cleaning: It's time for a little magic!

Cleaning the oven can be an easy scrub free task with just a little bit of work. Silverline makes the cleaning of the ovens much easier by offering various cleaning solutions. They prolongs the life of your oven and help you save time every day to make your life easier in your kitchen.

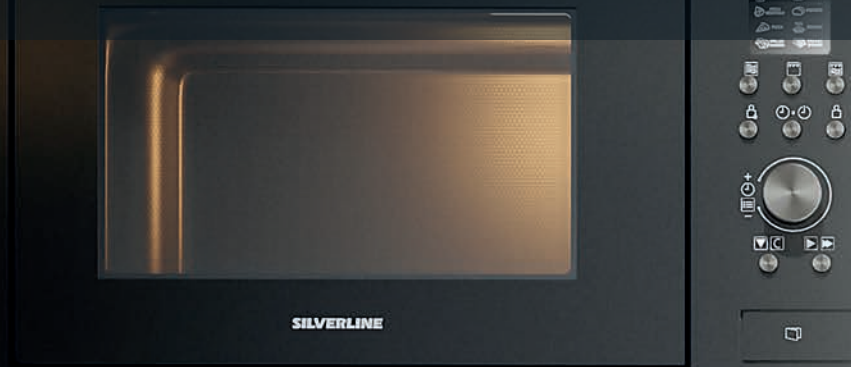

12:05 29°C



SILVERLINE



### SELF CLEAN +

The quick and easy option for effortless cleaning thanks to catalytic panels. The back and side wall panels absorb dirt that splashes from food.



### SELF CLEAN

Above advantage is available only for back wall.



### SOFT CLOSE

It slows down the movement of the door and ensures your oven door closes gently.



### SOFT OPEN CLOSE

It slows down the movement of the door and ensures your oven door opens and closes gently.



### EASY CLEANING

The easy cleaning for day to day maintenance.

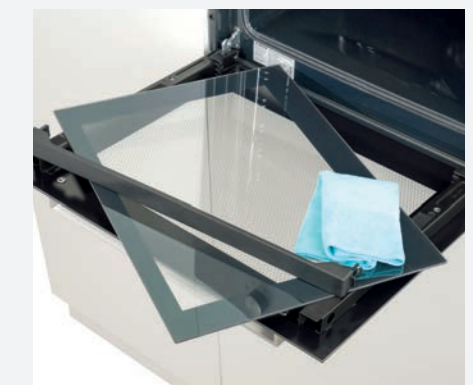

### EASY EXTRACT

It enables to remove easily the front glass panels of the oven.



### ANTI - FINGER INOX

Anti-finger inox surface provides comfort in cleaning.



### STEAM CLEAN

The heat turns water into steam and softens food residuals for easy cleaning.

# LEGENDS

## OVENS

-  **BOTTOM RESISTANT:** To cook something which needs to crisp on the base but stay moist on the top. This function is best suited for foods which need more temperature at the base such as pastry and pizzas and it is great for gently cooking stews and casseroles.
-  **TOP RESISTANT:** Top resistant creates the perfect roasting or crisping effect. Helps with the browning of dishes such as those topped with cheese or potatoes, under a less fiery heat than grill.
-  **TOP RESISTANT + BOTTOM RESISTANT:** Cooks items which sit in the centre of the oven best. Use this conventional heating mode for roasting meat and vegetables or baking cakes.
-  **TOP RESISTANT + BOTTOM RESISTANT+ FAN:** Food is cooked evenly and quickly all around thanks to lower and upper resistants and the fan are simultaneously on. This mode is most suitable for delicate cooking such as cakes, pastries, biscuits.
-  **TOP RESISTANT + GRILL:** Food can be cooked extremely quickly using both the top resistant and the grill.
-  **TOP RESISTANT + GRILL + FAN :** Top resistant, grill and fan are activated simultaneously, so heat is spread throughout the oven and radiated over the grill's surface area. It is ideal for larger portions.
-  **TOP RESISTANT + FAN + RING HEATER + BOTTOM RESISTANT :** Top and bottom resistants, turbo fan and ring heater (located around the turbo fan) are activated simultaneously. It provides proper heat distribution for uniform cooking and convenient for cooking up to 3 trays.
-  **RING HEATER + FAN :** It is used for one or more levels cooking and frying. Ring heater and turbo fan are activated.
-  **DEFROST :** It ensures that the food defrosts in a couple of minutes without losing its nutritional value.
-  **BOOSTER:** The booster function is used for quick pre-heating to reach the desired cooking temperature. (It is not suitable for cooking food.)
-  **GRILL:** Grill resistant is used especially for food to be fried.
-  **FAN + BOTTOM RESISTANT :** For preparing pizza and dishes which require a lot of heat from underneath. The bottom heating element and the fan are activated.
-  **GRILL + FAN:** This indicates the simultaneous activation of the grill and the turbo fan and enables the cooking of small portions of white and red meat, sausage, etc.
-  **GRILL + FAN + BOTTOM RESISTANT :** Appropriate for roasts and cakes. The fan spreads the heat uniformly inside the oven.
-  **TURN SPIT (GRILL + SPIT) :** It is used for rotisserie such as roasted chicken etc.
-  **TURN SPIT + (TOP RESISTANT + GRILL + SPIT) :** It is used for rotisserie such as roasted chicken etc. It is ideal for larger portions.
-  **LIGHT:** All ovens have oven lamps but the oven lamp can be activated with an independent button in the models bearing this symbol.
-  **ECO ( FAN + RING HEATER ) :** More energy saving function for one or more levels cooking and frying. Ring heater and turbo fan are activated.
-  **STEAM CLEAN:** The heat turns water into steam and softens food residuals for easy cleaning.
-  **PYROLYTIC CLEAN:** It heats the inside of your oven to temperatures upwards of 480°C, turns food residual to ash.
-  **KEEP WARM :** Used for keeping food warm at a temperature ready for serving for a long period of time.
-  **GRILL + BOTTOM RESISTANT :** Special for roasts. It can be used for any piece, whatever its size.
-  **TOP FIRE + BOTTOM FIRE (GAS FURNACE) :** Top and bottom elements are activated.
-  **TOP FIRE (GAS FURNACE) :** Top element is activated.
-  **BOTTOM FIRE (GAS FURNACE) :** Bottom element is activated.
-  **IGNITION (GAS FURNACE) :** Automatic ignition for gas area.



# MULTIFUNCTION ELECTRIC OVENS



S5 T - BO65T5B01



S5 T - BO65T5X01



S5 T - BO65T5W01



S5 T - BO65T5S01



S5 T - BO65T5M01



<b>Oven Type</b>	Built-in Electric Oven 72 liter A+ Energy class
<b>Cooking Functions</b>	14 functions 3D Airmove Pizza Chef Rapid pre-heating Maxi grill, thermostat, turbo fan Keep warm function Eco mode for energy saving Cooling fan
<b>Cleaning</b>	Self Clean+ Steam Clean Easy Extract Anti-finger inox (BO6505X02)
<b>Comfort</b>	Advanced LED screen touch button control Screen child lock Removable side racks 2 telescopic rails Oven light Meat probe which enables to measure the meat's cooking degree Triple glass door (Cool Door) Soft Close Door
<b>Accessories</b>	1 chrome grid, 1 deep and 1 standard tray Airfry tray (optional) Pizza stone (optional)
<b>Dimensions</b>	595x547x595

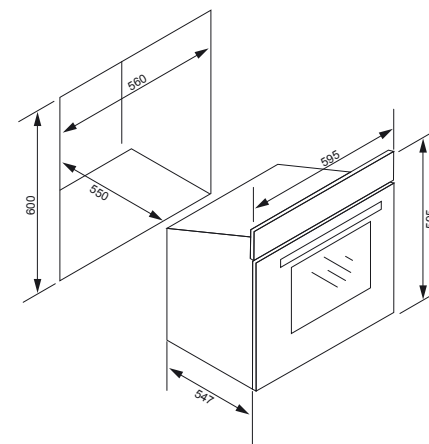
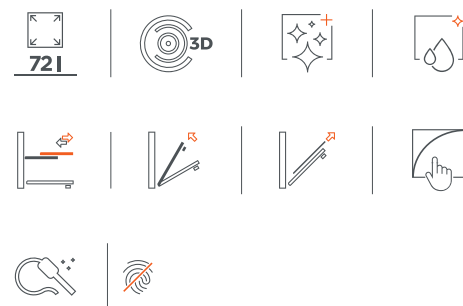

<b>Oven Type</b>	Built-in Electric Oven 72 liter A+ Energy class
<b>Cooking Functions</b>	14 functions 3D Airmove Pizza Chef Rapid pre-heating Maxi grill, thermostat, turbo fan Keep warm function Eco mode for energy saving Cooling fan
<b>Cleaning</b>	Self Clean+ Steam Clean Easy Extract
<b>Comfort</b>	Advanced LED screen touch button control Screen child lock Removable side racks 2 telescopic rails Oven light Meat probe which enables to measure the meat's cooking degree Triple glass door (Cool Door) Soft Close Door
<b>Accessories</b>	1 chrome grid, 1 deep and 1 standard tray Airfry tray (optional) Pizza stone (optional)
<b>Dimensions</b>	595x547x595

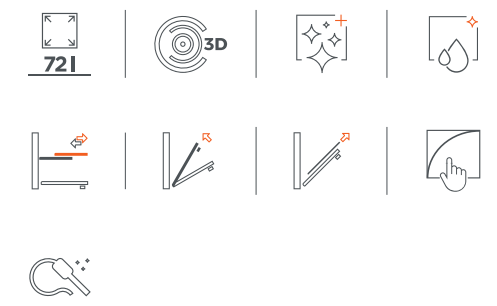

# MULTIFUNCTION ELECTRIC OVENS



S5 - BO6505B01

S5 - BO6505X01

S5 - BO6505W01



<b>Oven Type</b>	Built-in Electric Oven 72 liter A+ Energy class
<b>Cooking Functions</b>	14 functions 3D Airmove Pizza Chef Rapid pre-heating Maxi grill, thermostat, turbo fan Keep warm function Eco mode for energy saving Cooling fan
<b>Cleaning</b>	Self Clean+ Steam Clean Easy Extract Anti-finger inox (BO6505X01)
<b>Comfort</b>	Advanced LED screen touch button control Endless ring navigator knob control Screen child lock Removable side racks 2 telescopic rails Oven light Meat probe which enables to measure the meat's cooking degree Triple glass door (Cool Door) Soft Close Door
<b>Accessories</b>	1 chrome grid, 1 deep and 1 standard tray Airfry tray (optional) Pizza stone (optional)
<b>Dimensions</b>	595x547x595

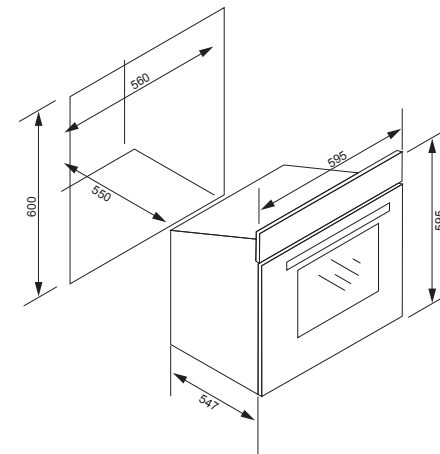
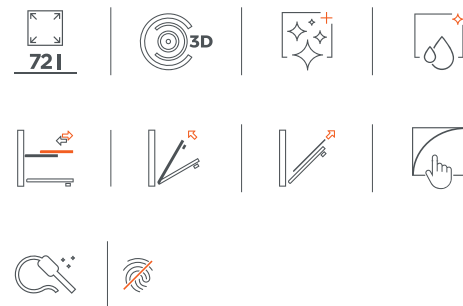

# MULTIFUNCTION ELECTRIC OVENS



S5 - BO6505S01

S5 - BO6505M01



<b>Oven Type</b>	Built-in Electric Oven 72 liter A+ Energy class
<b>Cooking Functions</b>	14 functions 3D Airmove Pizza Chef Rapid pre-heating Maxi grill, thermostat, turbo fan Keep warm function Eco mode for energy saving Cooling fan
<b>Cleaning</b>	Self Clean+ Steam Clean Easy Extract
<b>Comfort</b>	Advanced LED screen touch button control Endless ring navigator knob control Screen child lock Removable side racks 2 telescopic rails Oven light Meat probe which enables to measure the meat's cooking degree Triple glass door (Cool Door) Soft Close Door
<b>Accessories</b>	1 chrome grid, 1 deep and 1 standard tray Airfry tray (optional) Pizza stone (optional)
<b>Dimensions</b>	595x547x595

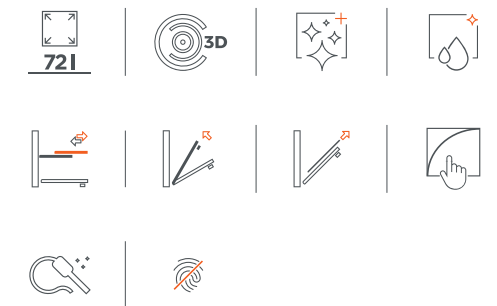

# Steam Technology

Pastries with  
Steam Technology!  
**Crispy on the outside  
and soft on the inside.**



## **Crispy on the outside and soft on the inside!**

Silverline S4 Steam Assisted Ovens offer the feature of adding water during cooking without opening the oven door, preventing moisture loss for your meals while preparing crispy outside and soft inside.

# Sfry Technology

Healthy and Practical  
Frying with Sfry  
Technology!

With Sfry Technology and a specially designed steel tray, hot air circulates around the food, making it crisper.

Thanks to its ability to cook in one go without opening the oven door, it allows you to make healthy fries that are crispy on the outside and soft and healthy on the inside. You can use just a teaspoon or no oil at all!

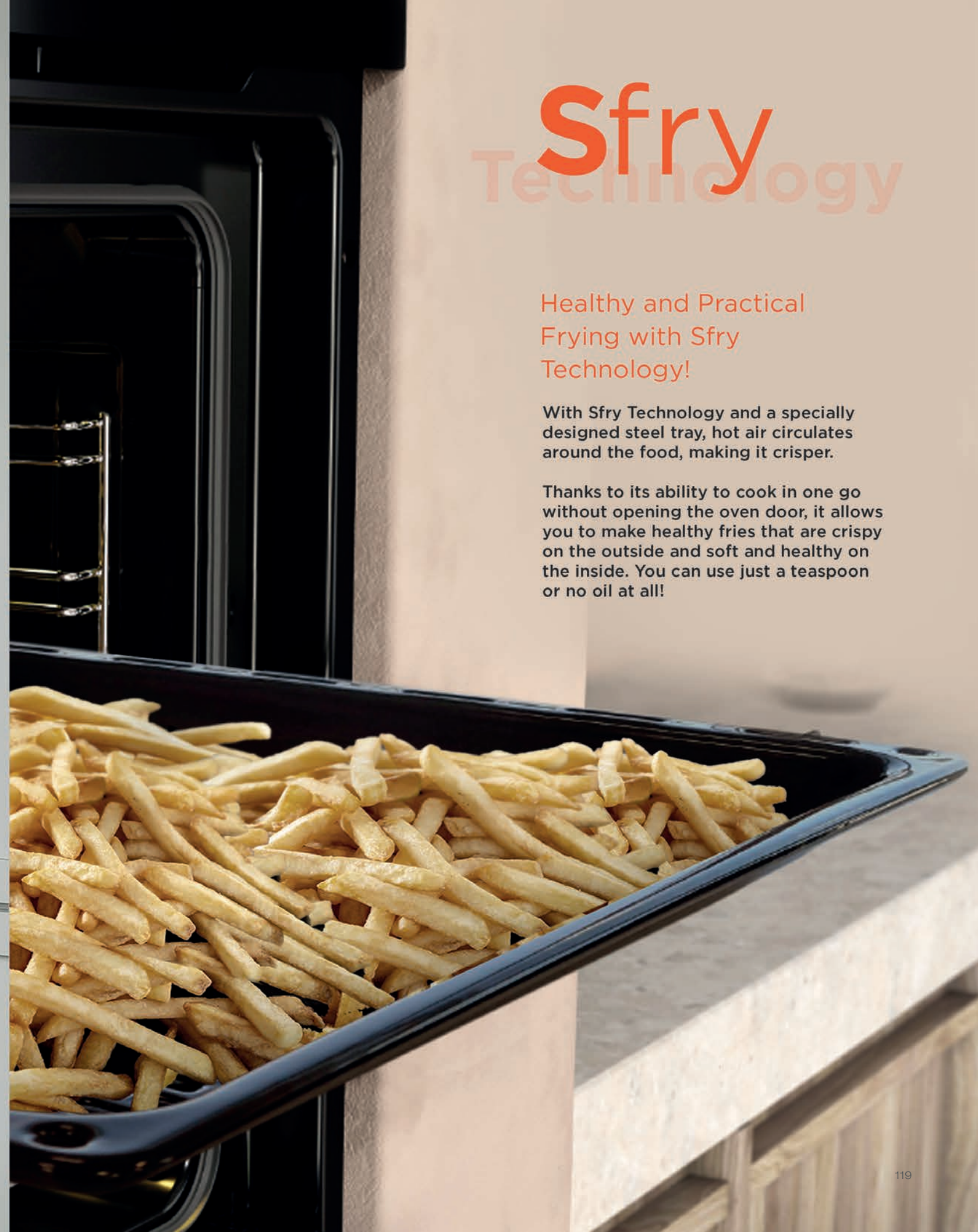

# STEAM ASSISTED OVENS



S4 Steam  
BO65P4B01

S4 Steam  
BO65P4X01

S4 Steam  
BO65P4W01

S4 Steam  
BO65P4S01

S4 Steam  
BO65P4M01



<b>Oven Type</b>	Built-in Electric Oven 72 liter A Energy class
<b>Cooking Functions</b>	8 functions 3D Airmove Steam Cooking Rapid pre-heating Maxi grill, thermostat, turbo fan Cooling fan
<b>Cleaning</b>	Self Clean Steam Clean Easy Extract Anti-finger inox (BO6504X01)
<b>Comfort</b>	Advanced digital timer - Alarm and time programmer 2 push-pull knobs Screen child lock Removable side racks Telescopic rail Oven light Double glass door
<b>Accessories</b>	1 chrome grid, 1 deep, 1 standard and 1 airfry tray
<b>Dimensions</b>	595x547x595

<b>Oven Type</b>	Built-in Electric Oven 72 liter A Energy class
<b>Cooking Functions</b>	8 functions 3D Airmove Steam Cooking Rapid pre-heating Maxi grill, thermostat, turbo fan Cooling fan
<b>Cleaning</b>	Self Clean Self Clean + Steam Clean Easy Extract
<b>Comfort</b>	Advanced digital timer - Alarm and time programmer 2 push-pull knobs Screen child lock Removable side racks Telescopic rail Oven light Double glass door
<b>Accessories</b>	1 chrome grid, 1 deep, 1 standard and 1 airfry tray
<b>Dimensions</b>	595x547x595

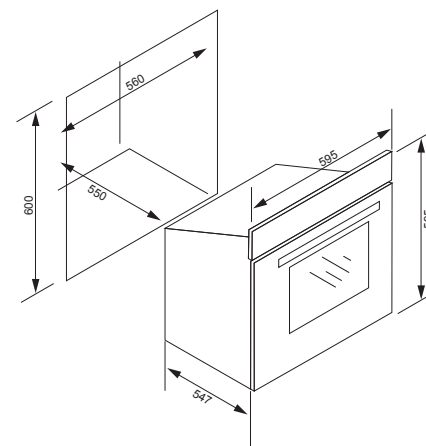
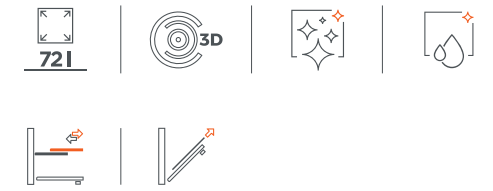
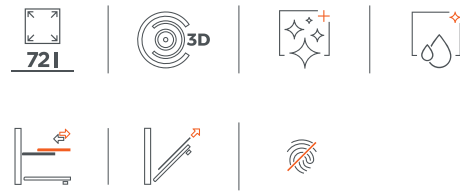

# MULTIFUNCTION ELECTRIC OVENS



S4 - BO6504B01



S4 - BO6504X01



S4 - BO6504W01



S4 - BO6504S01



S4 - BO6504M01



<b>Oven Type</b>	Built-in Electric Oven 72 liter A Energy class
<b>Cooking Functions</b>	8 functions 3D Airmove Rapid pre-heating Maxi grill, thermostat, turbo fan Cooling fan
<b>Cleaning</b>	Self Clean Steam Clean Easy Extract Anti-finger inox (BO6504X01)
<b>Comfort</b>	Advanced digital timer - Alarm and time programmer 2 push-pull knobs Screen child lock Removable side racks Telescopic rail Oven light Double glass door
<b>Accessories</b>	1 chrome grid, 1 deep and 1 standard tray Airfry tray (optional)
<b>Dimensions</b>	595x547x595

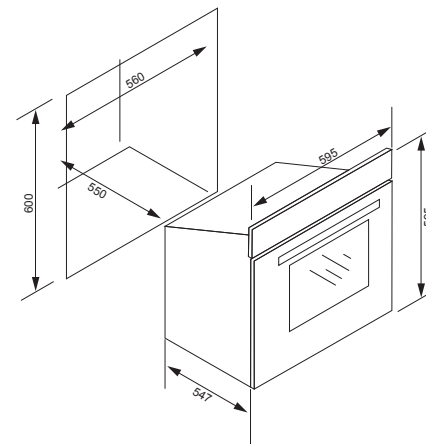
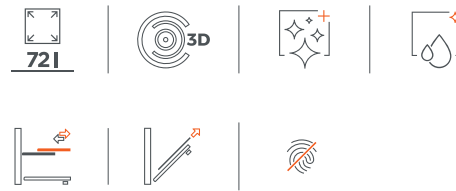

<b>Oven Type</b>	Built-in Electric Oven 72 liter A Energy class
<b>Cooking Functions</b>	8 functions 3D Airmove Rapid pre-heating Maxi grill, thermostat, turbo fan Cooling fan
<b>Cleaning</b>	Self Clean Self Clean + Steam Clean Easy Extract
<b>Comfort</b>	Advanced digital timer - Alarm and time programmer 2 push-pull knobs Screen child lock Removable side racks Telescopic rail Oven light Double glass door
<b>Accessories</b>	1 chrome grid, 1 deep and 1 standard tray Airfry tray (optional)
<b>Dimensions</b>	595x547x595

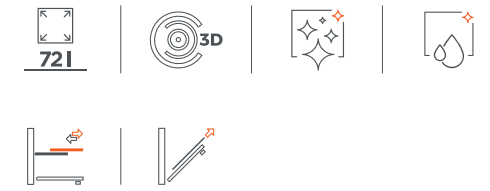

# MULTIFUNCTION ELECTRIC OVENS



S3 - BO6503B01



S3 - BO6503X01



S3 - BO6503W01



S3 - BO6503S01



S3 - BO6503M01



<b>Oven Type</b>	Built-in Electric Oven 72 liter A Energy Class
<b>Cooking Functions</b>	8 functions 3D Airmove Rapid pre-heating Maxi grill, thermostat, turbo fan Cooling fan
<b>Cleaning</b>	Self Clean Steam Clean Easy Extract Anti-finger inox (BO6503X01)
<b>Comfort</b>	Mechanical timer 3 push-pull knobs Removable side racks Telescopic rail Oven light Double glass door
<b>Accessories</b>	1 chrome grid, 1 deep and 1 standard tray Airfry tray (optional)
<b>Dimensions</b>	595x547x595

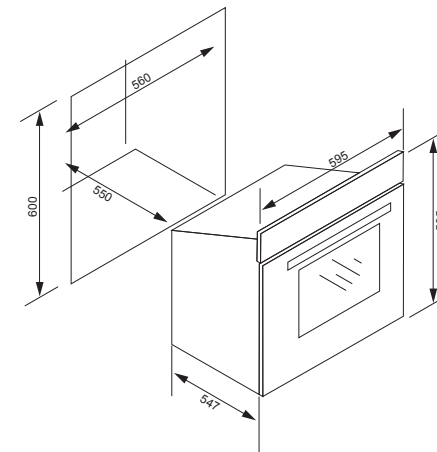
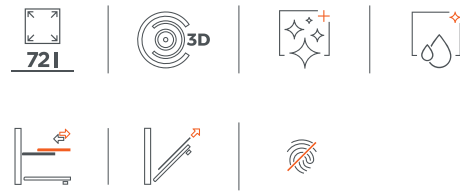

<b>Oven Type</b>	Built-in Electric Oven 72 liter A Energy Class
<b>Cooking Functions</b>	8 functions 3D Airmove Rapid pre-heating Maxi grill, thermostat, turbo fan Cooling fan
<b>Cleaning</b>	Self Clean Steam Clean Easy Extract
<b>Comfort</b>	Mechanical timer 3 push-pull knobs Removable side racks Telescopic rail Oven light Double glass door
<b>Accessories</b>	1 chrome grid, 1 deep and 1 standard tray Airfry tray (optional)
<b>Dimensions</b>	595x547x595

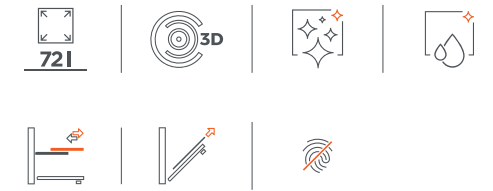



# MULTIFUNCTION ELECTRIC OVENS



S2 - BO6502B02

S2 - BO6502X02

S2 - BO6502W02

S2 - BO6502S02



S1 - BO6501B01

S1 - BO6501X01

S1 - BO6501W01



<b>Oven Type</b>	Built-in Electric Oven 72 liter A Energy Class
<b>Cooking Functions</b>	6 functions Rapid pre-heating Maxi grill, thermostat, turbo fan Cooling fan
<b>Cleaning</b>	Steam Clean Easy Extract Anti-finger inox ( BO6502X01)
<b>Comfort</b>	Digital timer - Alarm and time programmer 2 standard knobs Removable side racks Oven light Double glass door
<b>Accessories</b>	1 chrome grid, 1 deep and 1 standard tray
<b>Dimensions</b>	595x547x595

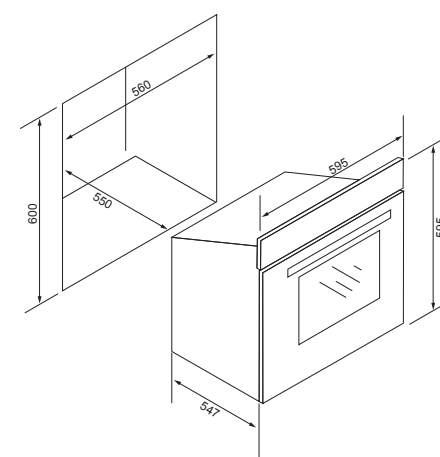

<b>Oven Type</b>	Built-in Electric Oven 72 liter A Energy Class
<b>Cooking Functions</b>	6 functions Rapid pre-heating Maxi grill, thermostat, turbo fan Cooling fan
<b>Cleaning</b>	Steam Clean Easy Extract Anti-finger inox ( BO6501X01)
<b>Comfort</b>	2 standard knobs Removable side racks Oven light Double glass door
<b>Accessories</b>	1 chrome grid, 1 deep and 1 standard tray
<b>Dimensions</b>	595x547x595

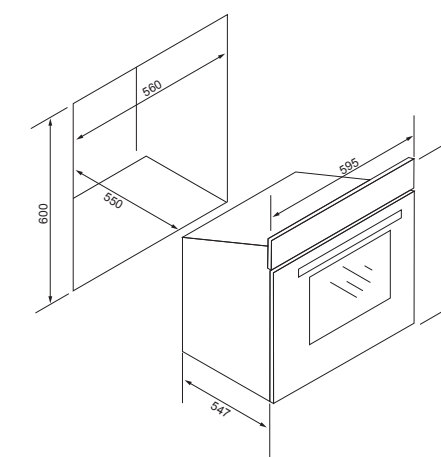

## BUILT-IN ELECTRIC OVENS



BO6284B01



<b>Oven Type</b>	Built-in Electric Oven 72 liter A+ Energy class
<b>Cooking Functions</b>	12 functions / 3D Airmove / Pizza Chef Maxi grill, thermostat, turbo fan / Eco mode for energy saving / Rapid pre-heating / Top + Bottom / Ring heater + Fan / Defrost / Top + Fan / Bottom / Light / Dough Proving
<b>Cleaning</b>	Easy Extract Pyrolytic (function)
<b>Comfort</b>	Advanced White LED screen touch control Screen child lock Removable side racks Telescopic runners Oven light 4 glass door Cooling fan Low-e Glass
<b>Accessories</b>	1 chrome grid and 1 deep tray
<b>Dimensions</b>	595x546x596

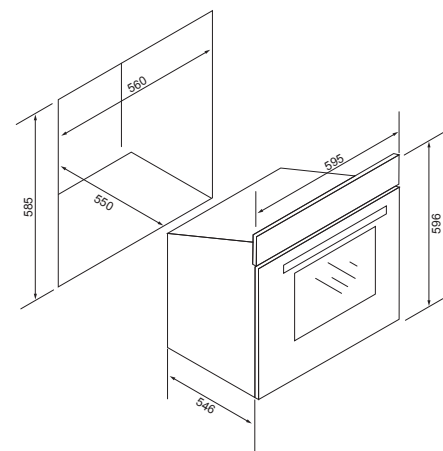

BO6288B01



<b>Oven Type</b>	Built-in Electric Oven 70 liter A Energy class
<b>Cooking Functions</b>	9 functions / 3D Airmove / Maxi grill, thermostat, turbo fan / Eco mode for energy saving / Top + Bottom / Ring heater + Fan / Defrost / Top + Fan / Bottom / Light
<b>Cleaning</b>	Easy Extract Pyrolytic (function)
<b>Comfort</b>	Advanced White LED screen touch control Screen child lock Removable side racks Telescopic runners Oven light 4 glass door Cooling fan Low-e Glass
<b>Accessories</b>	1 chrome grid and 1 deep tray
<b>Dimensions</b>	595x575x595

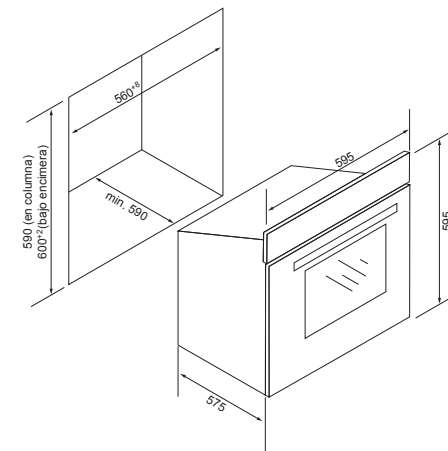

## BUILT-IN ELECTRIC OVEN WITH MICROVAWE / BUILT-IN WARMING DRAWER



BO6283B01



<b>Oven Type</b>	Built-in Electric Oven with Microwave 50 liter
<b>Cooking Functions</b>	Auto menu: 13 (fresh vegetables, potato peeled/cooked, baked potatoes, chicken pieces, apple pie, quiche, reheat soup, reheat plate, reheat sauce, frozen pizza, frozen chips, lasagna) Microwave / Pizza Chef / Rapid pre-heating Maxi grill, mini grill, thermostat, turbo fan Top + Bottom / Ring heater + Fan / Top + Bottom + Fan / Defrost / Bottom / Light / Dough Proofing
<b>Cleaning</b>	/
<b>Comfort</b>	Advanced White LED screen touch control Screen child lock (function) Oven light Triple glass door Cooling fan
<b>Accessories</b>	1 chrome grid, 1 glass and 1 standard tray
<b>Dimensions</b>	595x568x454

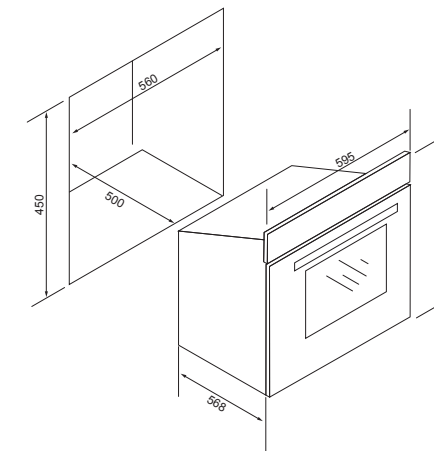

H19003B01



<b>Oven Type</b>	Built-in Warming Drawer 22 liter
	Push Open Door Black Glass + Stainless Steel Out Look Stainless Steel Cavity
<b>Functions</b>	Glass/cup heating (40/45/50/60°C) Dishes/plates heating (60/65/70/75/80°C) Keep warm (60/65/70/75/80°C) Yoghourt (40°C 6-8 hours) Defrost (30°C) Slow cook (60°C for meat mid cooked) Melt chocolate (60°C) Sterilizing (80°C 30-60 min)
<b>Comfort</b>	Advanced White LED Screen Touch Control Adjustable temperature range 30-80°C Up to 6 hr. Timer
<b>Dimensions</b>	595x561mm (Oven + Frame Overall Exterior Dimensions)

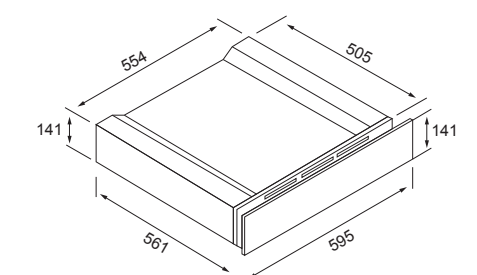

# GAS OVENS



**BO6085X01**



<b>Oven Type</b>	Built-in Gas Oven 45 liter Gas Top and Gas Bottom Heating
<b>Cooking Functions</b>	3 functions Turnspit (Optional) Cooling fan
<b>Cleaning</b>	/
<b>Comfort</b>	Digital timer - Alarm and time programmer 2 standard knobs Automatic Ignition Flame Failure Device Oven light Double glass door
<b>Accessories</b>	1 chrome grid, 1 deep tray
<b>Dimensions</b>	595x540x595

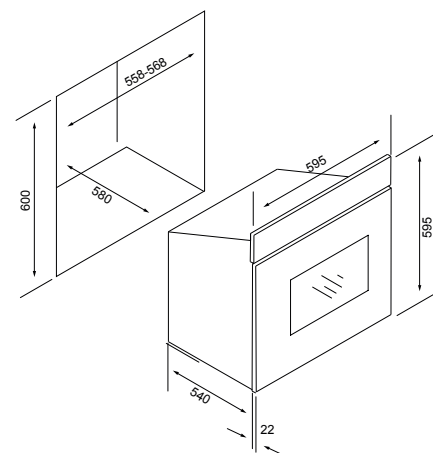

**BO6087X01**



<b>Oven Type</b>	Built-in Gas Oven 45 liter Gas Top and Gas Bottom Heating
<b>Cooking Functions</b>	3 functions Turnspit (Optional) Cooling fan
<b>Cleaning</b>	/
<b>Comfort</b>	2 standard knobs Automatic Ignition Flame Failure Device Oven light Double glass door
<b>Accessories</b>	1 chrome grid, 1 deep tray
<b>Dimensions</b>	595x540x595

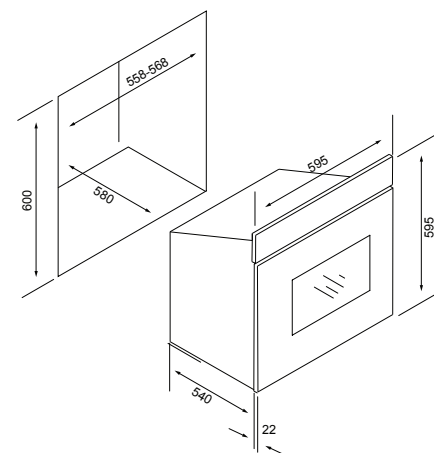

**BO6277X01**



<b>Oven Type</b>	Built-in Gas Oven 88 liter Gas Top and Gas Bottom Heating
<b>Cooking Functions</b>	3 functions Turnspit Turbo fan
<b>Cleaning</b>	/
<b>Comfort</b>	Mechanical timer Oven light Double glass door
<b>Accessories</b>	1 chrome grid, 1 standard tray
<b>Dimensions</b>	895x551x594

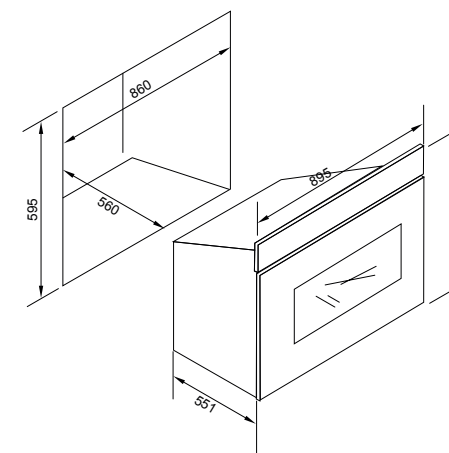

**BO6277B01**



<b>Oven Type</b>	Built-in Gas Oven 88 liter Gas Top and Gas Bottom Heating
<b>Cooking Functions</b>	3 functions Turnspit Turbo fan
<b>Cleaning</b>	/
<b>Comfort</b>	Mechanical timer Oven light Double glass door
<b>Accessories</b>	1 chrome grid, 1 standard tray
<b>Dimensions</b>	895x551x594

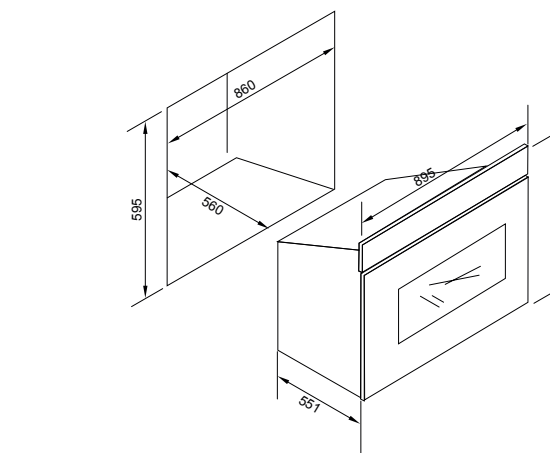

## FREE STANDING COOKERS

FO6263W01



FO6263I01



<b>Oven Type</b>	Free-Standing Gas Oven 50x60, 50x60 or 60x60 size options Electric Top and Gas Bottom Heating
<b>Cooking Functions</b>	4 Gas Burners Turnspit
<b>Cleaning</b>	/
<b>Comfort</b>	Glass Top Lid Enamel Pan Support Automatic Ignition Oven light Double Glass Oven Door Adjustable feet
<b>Accessories</b>	1 chrome grid, 1 standard tray
<b>Dimensions</b>	/

FO6278W01



FO6279W01



<b>Oven Type</b>	Free-Standing Electric Oven 50x60 or 60x60 size options
<b>Cooking Functions</b>	4 Hot Plates (FO6278W01) 4 VTC zones (FO6279W01) Turnspit (Optional) Thermostat Turbo fan (Optional) (FO6278W01)
<b>Cleaning</b>	/
<b>Comfort</b>	Oven light Double Glass Oven Door
<b>Accessories</b>	1 chrome grid, 1 standard tray
<b>Dimensions</b>	/



# MICROWAVES

The meals you like in just one touch! Silverline offers wide range built-in microwave ovens that complete your kitchen design.



# MICROWAVE OVENS



**8** Program | **34** Liter | **5** Level

## MW9025X01

<b>Microwave Type</b>	Built-In Microwave 34 Lt Capacity
<b>Cooking Function</b>	Microwave + Grill cooking Multi-cooking function 8 auto cooking programs 2 combination cooking programs
<b>Comfort</b>	95 Minute timer 5 microwave power levels Cooking end signal Quick start Defrost by weight and time Door Release Button
<b>Safety</b>	Child safety lock
<b>Others</b>	Anti finger stainless steel control panel and front exterior White colour LED digital display 1550W input microwave power 1000 W grill power Stainless steel interior Metal rack Glass turntable Silver Buttons + Aluminum Dial Push Pull Knob



**8** Program | **25** Liter | **5** Level

## MW9013X01

<b>Microwave Type</b>	Built-In Microwave 25 Lt Capacity
<b>Cooking Function</b>	Microwave + Grill cooking Multi-cooking function Pre-set Cooking 8 auto cooking programs 2 combination cooking programs (microwave & grill)
<b>Comfort</b>	Digital Clock / 95 min. non-segment digital timer 5 microwave power levels Cooking end signal Quick start Auto defrost function Push-out door
<b>Safety</b>	Child safety lock
<b>Others</b>	1450W input microwave power 1000 W grill power Stainless steel interior / frontal panel Metal rack Stainless steel built-in frame Glass turntable



**8** Program | **25** Liter | **5** Level

## MW9024S01

<b>Microwave Type</b>	Built-In Microwave 25 Lt Capacity
<b>Cooking Function</b>	Microwave + Grill cooking Multi-cooking function 8 auto cooking programs 2 combination cooking programs (microwave & grill)
<b>Comfort</b>	Digital Clock / 95 min. non-segment digital timer 5 microwave power levels Cooking end signal Quick start Defrost by weight and time
<b>Safety</b>	Child safety lock
<b>Others</b>	White colour LED digital display 1450W input microwave power 1000 W grill power Stainless steel interior / window glass frontal panel Metal rack Glass turntable Aluminum Handle Door



**8** Program | **23** Liter | **5** Level

## MW9018B01

<b>Microwave Type</b>	Built-In Microwave 23 Lt Capacity
<b>Cooking Function</b>	Microwave + Grill cooking Multi-cooking function 8 auto cooking programs 2 combination cooking programs (microwave & grill) Pre-set Cooking
<b>Comfort</b>	Digital Clock / 95 min. non-segment digital timer 5 microwave power levels Cooking end signal Quick start Auto defrost function
<b>Safety</b>	Child safety lock
<b>Others</b>	1400W input microwave power 1000 W grill power Metal rack Glass turntable Stainless steel interior Black glass built-in frame



**8** Program | **23** Liter | **5** Level

## MW9018X01

<b>Microwave Type</b>	Built-In Microwave 23 Lt Capacity
<b>Cooking Function</b>	Microwave + Grill cooking Multi-cooking function 8 auto cooking programs 2 combination cooking programs (microwave & grill) Pre-set Cooking
<b>Comfort</b>	Digital Clock / 95 min. non-segment digital timer 5 microwave power levels Cooking end signal Quick start Auto defrost function
<b>Safety</b>	Child safety lock
<b>Others</b>	1400W input microwave power 1000 W grill power Metal rack Glass turntable Stainless steel interior Black glass built-in frame



**8** Program | **23** Litre | **5** Seviye

## MW9018W01

<b>Microwave Type</b>	Built-In Microwave 23 Lt Capacity
<b>Cooking Function</b>	Microwave + Grill cooking Multi-cooking function 8 auto cooking programs 2 combination cooking programs (microwave & grill) Pre-set Cooking
<b>Comfort</b>	Digital Clock / 95 min. non-segment digital timer 5 microwave power levels Cooking end signal Quick start Auto defrost function
<b>Safety</b>	Child safety lock
<b>Others</b>	1400W input microwave power 1000 W grill power Metal rack Glass turntable Stainless steel interior Black glass built-in frame

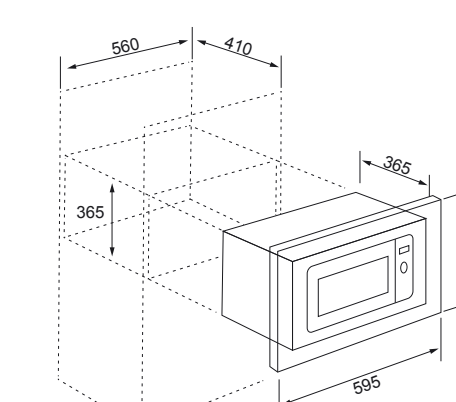
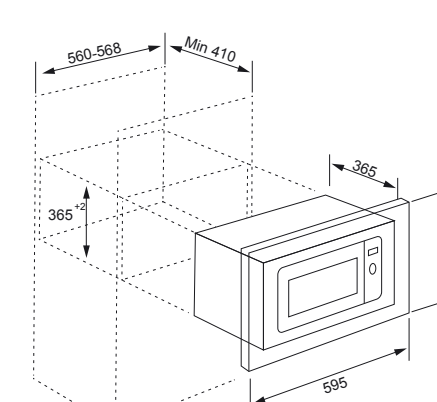
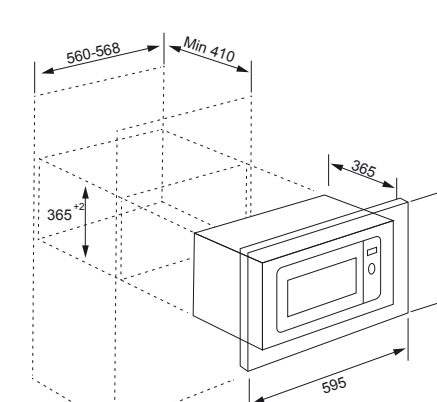
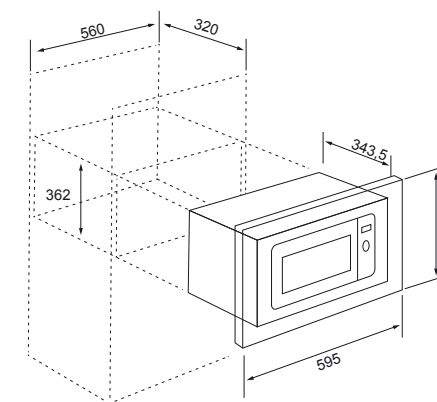
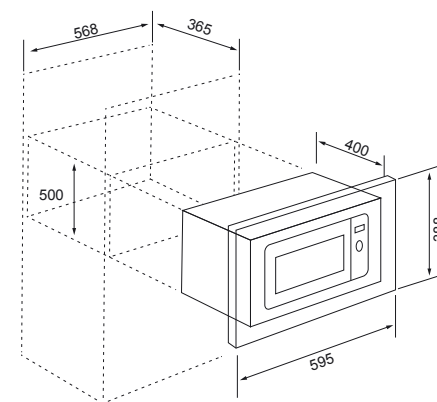
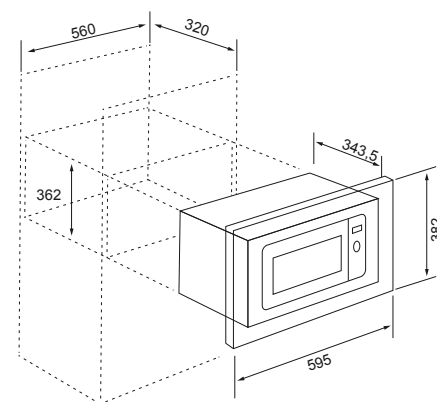

# MICROWAVE OVENS



**8** Program  
**25** Liter  
**5** Level

## MWE-35 IB

<b>Microwave Type</b>	Built-In Microwave 25 Lt Capacity
<b>Cooking Function</b>	Touch control microwave + Oven with grill 8 auto cooking programs
<b>Comfort</b>	95 Minute timer Touch control and touch open door Defrost by weight / time
<b>Safety</b>	Child safety lock
<b>Others</b>	Power Input 1450W Power output 900W 1000W grill 315mm turntable SUS Cavity Door glass Acrylic control panel + anti-finger SUS strips decoration White LED display



**8** Program  
**25** Liter  
**5** Level

## MWE-35 W

<b>Microwave Type</b>	Built-In Microwave 25 Lt Capacity
<b>Cooking Function</b>	Touch control microwave + Oven with grill 8 auto cooking programs
<b>Comfort</b>	95 Minute timer Touch control and touch open door Defrost by weight / time
<b>Safety</b>	Child safety lock
<b>Others</b>	Power Input 1450W Power output 900W 1000W grill 315mm turntable SUS Cavity Door glass Acrylic control panel White LED display



**8** Program  
**25** Liter  
**5** Level

## MWE-35 G

<b>Microwave Type</b>	Built-In Microwave 25 Lt Capacity
<b>Cooking Function</b>	Touch control microwave + Oven with grill 8 auto cooking programs
<b>Comfort</b>	95 Minute timer Touch control and touch open door Defrost by weight / time
<b>Safety</b>	Child safety lock
<b>Others</b>	Power Input 1450W Power output 900W 1000W grill 315mm turntable SUS Cavity Door glass Acrylic control panel White LED display



**8** Program  
**20** Liter  
**5** Level

## MW9012X01

<b>Microwave Type</b>	Built-In Microwave 20 Lt Capacity
<b>Cooking Function</b>	Microwave + Grill cooking Multi-cooking function 8 auto cooking programs 2 combination cooking programs (microwave & grill) Pre-set Cooking
<b>Comfort</b>	Digital Clock / 95 min. non- segment digital timer 5 microwave power levels Cooking end signal Quick start Defrost by weight and time Auto reheat
<b>Safety</b>	Child safety lock
<b>Others</b>	1250W input microwave power 1000 W grill power Stainless steel interior / window glass frontal panel Stainless steel built-in frame Metal rack Glass turntable Anti finger Option without anti finger



**8** Program  
**20** Liter  
**6** Level

## MW9035B01

<b>Microwave Type</b>	Built-In Microwave 20 Lt Capacity
<b>Cooking Function</b>	Microwave + Grill cooking 8 auto cooking programs 2 combination cooking programs (microwave & grill) Express cooking Pre-set Cooking
<b>Comfort</b>	Digital clock 6 microwave power levels Cooking end signal Cooking timer Auto & Speed Defrost function
<b>Safety</b>	Child safety lock
<b>Others</b>	900 W grill power 700 W output microwave power Glass turntable Stainless steel interior

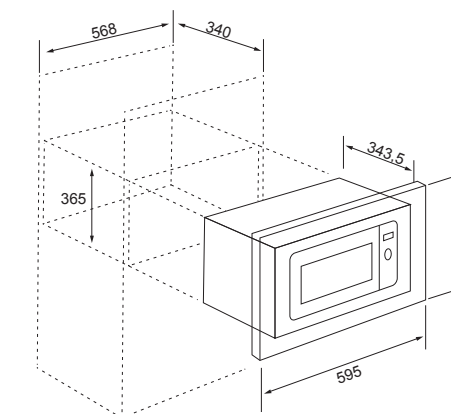
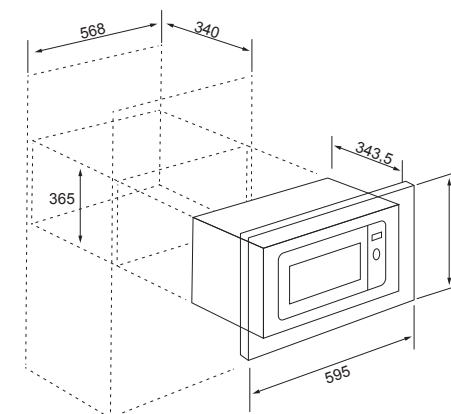
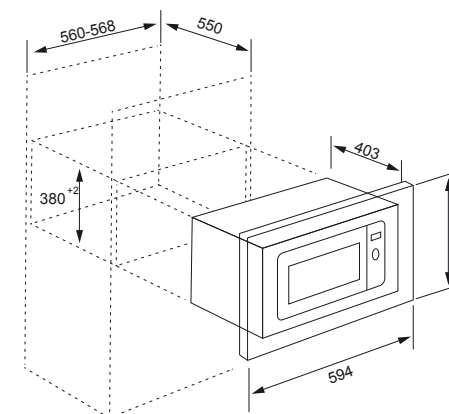
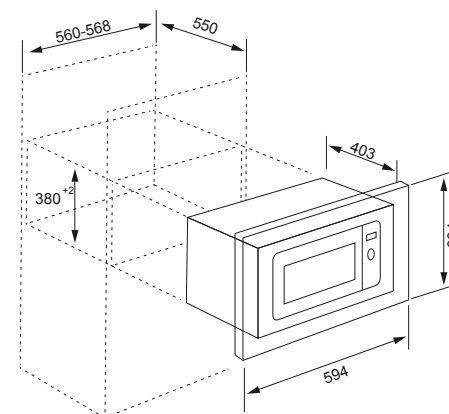
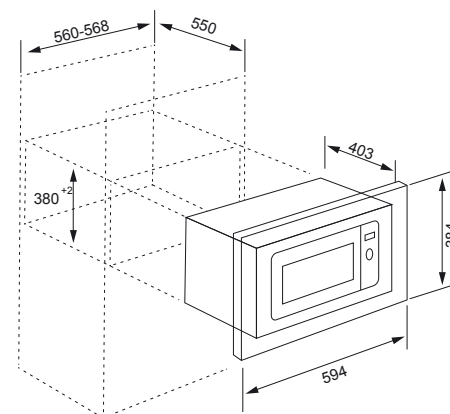



# HOBS

Very step on the path to culinary art forms a part of a whole.  
Strong designs, advanced technology, multi-functionality.





**GAS HOB**

Combustion of gas is used as the source of heat.



**VITROCERAMIC HOB**

Intensive heat - resistant and shockproof ceramic glass surface (Resistant up to 850°C)



**INDUCTION HOB**

It is the high-frequency electromagnetic feature which transforms the container into a heat generator rather than conveying the heat it generated to the container



**EASY CLEANING**

Easy cleaning for day to day maintenance.



**WIDTH**

The width of the oven. (30-90 cm)



**FIRING IGNITION**

Automatic ignition system.



**FIRE CONTROL**

Gives you precise, convenient fire control over all cooking zones.



**SMART CONNECT**

It is possible to control the various functions of the hood directly from the hob.



**GAS PROOF SAFETY**

It cuts off the gas supply immediately to ensure full safety.



**BRIDGE**

Two separate cooking zones can be used as a single and large surface.



**AFTER HEAT INDICATOR**

The post-heating indicator shows whether it is safe to touch the surface.



**TIME ASSISTANCE**

The function of the closure of timer closes all of hotplates safety when selected time expired.



**CHILD SCREEN LOCK**

The child safety lock inhibits all functions of the hob with a single button.



**BOOSTER**

This function is used to heat the oven rapidly; it is not suitable for cooking food.

# INDUCTION HOBS

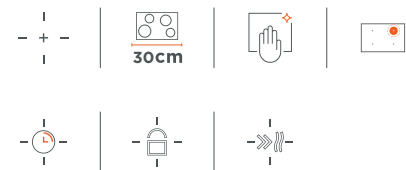

## IH8120B01

<b>Hob Features</b>	Built-in 30cm Black
<b>Comfort Features</b>	2 Radial Coil Booster Touch Control Timer
<b>Safety</b>	Child Safety Lock
<b>Other Features</b>	Product Dimensions (WxDxH): 290 x 520 x 58mm Cut Out Dimensions (WxDxH): 260 x 490mm Front Right Zone Size / Power: 180 / 2000 W (B 2300 W) Rear Right Zone Size / Power: 180 / 1800 W (B 2000 W) Maximum Power: 3600 W

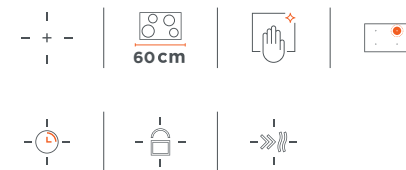
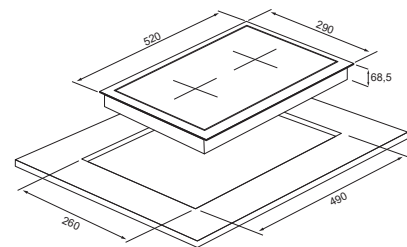

## IH8110B01

<b>Hob Features</b>	Built-in 60cm Black
<b>Comfort Features</b>	4 Induction Zones Booster Touch Control Timer
<b>Safety</b>	Child Safety Lock
<b>Other Features</b>	Product Dimensions (WxDxH): 590 x 520 x 56mm Cut Out Dimensions (WxDxH): 565 x 495mm Front Right Zone Size / Power: 180 / 2000 W (B 2300 W) Rear Right Zone Size / Power: 210 / 2300 W (B 2600 W) Front Left Zone Size / Power: 180 / 2000 W (B 2300 W) Rear Left Zone Size / Power: 180 / 2000 W (B 2300 W) Maximum Power: 6400 W

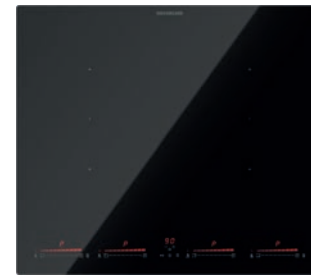
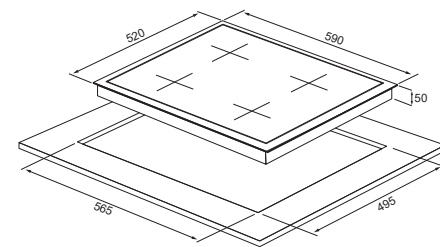

## IH8112B01

<b>Hob Features</b>	Built-in 60cm Black
<b>Comfort Features</b>	4 Induction Zones Booster Multi Slider Bridge Timer Keep Warm Pause and Go
<b>Safety</b>	Child Safety Lock Residual Heat Control Automatic Safety Switch Off
<b>Other Features</b>	Product Dimensions (WxDxH): 590 x 520 x 50mm Cut Out Dimensions (WxDxH): 565 x 495mm Front Right Zone Size / Power: 190x190mm- 2KW/2,8kW Rear Right Zone Size / Power: 190x190mm- 2KW/2,8kW Front Left Zone Size / Power: 190x190mm- 1,5KW/2kW Rear Left Zone Size / Power: 190x190mm- 1,5KW/2kW Maximum Power: 7200W

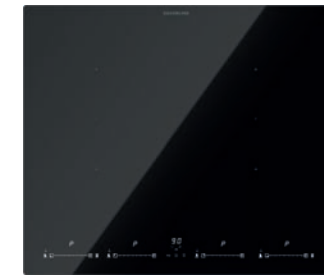
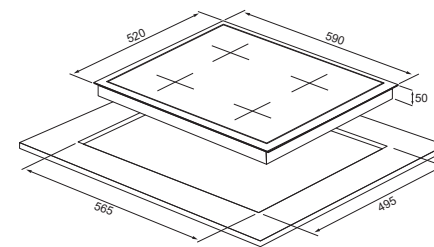

## IH8113B01

<b>Hob Features</b>	Built-in 60cm Black
<b>Comfort Features</b>	4 Induction Zones Booster Smart Control (Backlight) Bridge Timer Keep Warm Pause and Go
<b>Safety</b>	Child Safety Lock Residual Heat Control Automatic Safety Switch Off
<b>Other Features</b>	Product Dimensions (WxDxH): 590 x 520 x 50mm Cut Out Dimensions (WxDxH): 565 x 495mm Front Right Zone Size / Power: 190x190mm- 2KW/2,8kW Rear Right Zone Size / Power: 190x190mm- 2KW/2,8kW Front Left Zone Size / Power: 190x190mm- 1,5KW/2kW Rear Left Zone Size / Power: 190x190mm- 1,5KW/2kW Maximum Power: 7200W

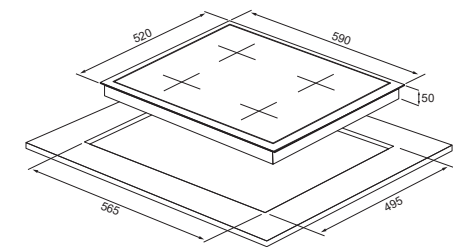



# VITRO CERAMIC HOBS



## VC8220B01

<b>Hob Features</b>	Built-in 30cm Black
<b>Comfort Features</b>	2 Induction Zones Booster Touch Control Timer Red Display
<b>Safety</b>	Child Safety Lock
<b>Other Features</b>	Product Dimensions (WxDxH): 290 x 520 x 51mm Cut Out Dimensions (WxDxH): 260 x 490mm Front Right Zone Size / Power: 140 / 1200 W Rear Right Zone Size / Power: 180 / 1800 W Maximum Power: 3000 W

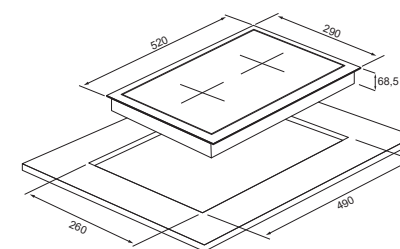

## VC8210B01

<b>Hob Features</b>	Built-in 60cm Black
<b>Comfort Features</b>	4 Induction Zones Booster Touch Control Timer Red Display
<b>Safety</b>	Child Safety Lock Residual Heat Indicator Automatic Shutdown
<b>Other Features</b>	Product Dimensions (WxDxH): 590 x 520 x 51mm Cut Out Dimensions (WxDxH): 565 x 495mm Front Right Zone Size / Power: 145 / 1200 W Rear Right Zone Size / Power: 2100 / 2250 W Front Left Zone Size / Power: 180 / 1800 W Rear Left Zone Size / Power: 180 / 1800 W Maximum Power: 7000 W

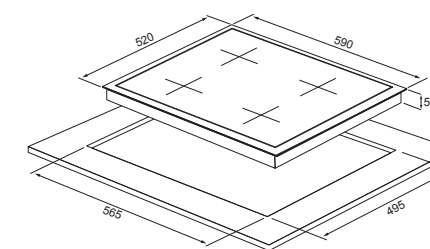

# MyFlame

WOK burners give intense fire and with its two rings, it spreads the heat from the inside to the outside. Thanks to this, it preserve the nutritional elements while cooking the foods. Saves time and energy while cooking with up to 9 level heat setting.

# MYFLAME HOBS

MyFlame



## CS5427B01

<b>Hob Features</b>	Built-in 60cm Black
<b>Comfort Features</b>	Cast Iron Pans Supports 4 Gas Burners Auto Ignition MY FLAME
<b>Safety</b>	Gas Safety Device
<b>Other Features</b>	Product Dimensions (WxDxH): 590 x 520 x 55mm Cut Out Dimensions (WxDxH): 560 x 490mm 1 x Rapid burner: 2900 W 2 x Semi-rapid burner: 1750 W 1 x Auxiliary burner: 1000 W Maximum Power: 7400 W Gas Type: NG NG/LPG Options

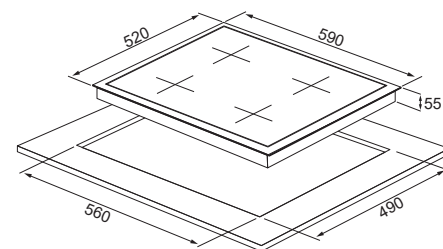

MyFlame



## CS5427W01

<b>Hob Features</b>	Built-in 60cm White
<b>Comfort Features</b>	Cast Iron Supports 4 Gas Burners Auto Ignition Front Mechanical Control MY FLAME
<b>Safety</b>	Gas Safety Device
<b>Other Features</b>	Product Dimensions (WxDxH): 750 x 520 x 55mm Cut Out Dimensions (WxDxH): 560 x 490mm 1 x Rapid burner: 2900 W 2 x Semi-rapid burner: 1750 W 1 x Auxiliary burner: 1000 W Maximum Power: 7400 W Gas Type: NG NG/LPG Options

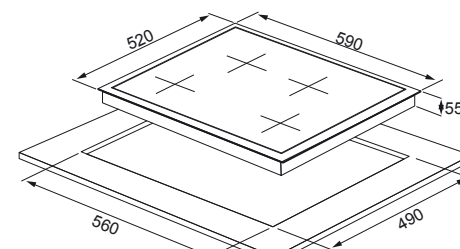

MyFlame

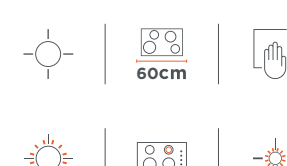
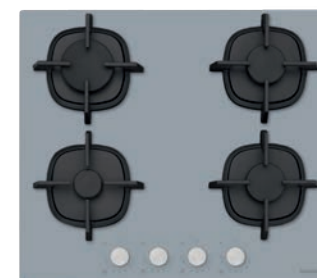

## CS5427S01

<b>Hob Features</b>	Built-in 60cm Grey
<b>Comfort Features</b>	Cast Iron Supports 4 Gas Burners Auto Ignition Front Mechanical Control
<b>Safety</b>	Gas Safety Device
<b>Other Features</b>	Product Dimensions (WxDxH): 590 x 520 x 55mm Cut Out Dimensions (WxDxH): 560 x 490mm 1 x Rapid burner: 2900 W 2 x Semi-rapid burner: 1750 W 1 x Auxiliary burner: 1000 W Maximum Power: 7400 W Gas Type: NG NG/LPG Options

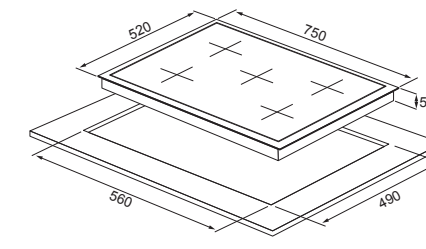

MyFlame

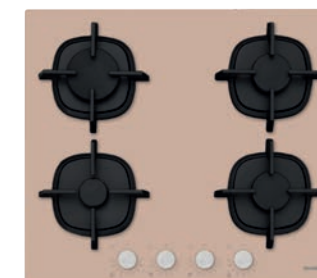

## CS5427M01

<b>Hob Features</b>	Built-in 60cm Mink
<b>Comfort Features</b>	Cast Iron Supports 4 Gas Burners Auto Ignition Front Mechanical Control MY FLAME
<b>Safety</b>	Gas Safety Device
<b>Other Features</b>	Product Dimensions (WxDxH): 590 x 520 x 55mm Cut Out Dimensions (WxDxH): 560 x 490mm 1 x Rapid burner: 2900 W 2 x Semi-rapid burner: 1750 W 1 x Auxiliary burner: 1000 W Maximum Power: 7400 W Gas Type: NG NG/LPG Options

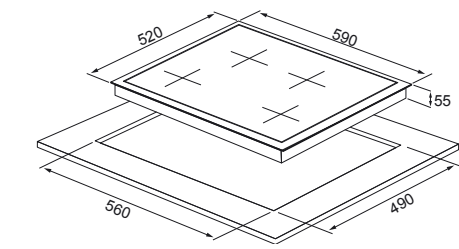

# MYFLAME HOBS

MyFlame

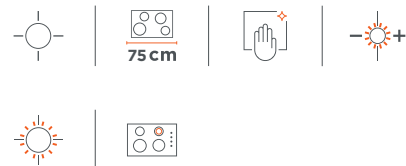

## CS5426B01

<b>Hob Features</b>	Built-in 75cm Black
<b>Comfort Features</b>	Cast Iron Pans Supports 4 Gas Burners 1 WOK Auto Ignition MY FLAME
<b>Safety</b>	Gas Safety Device
<b>Other Features</b>	Product Dimensions (WxDxH): 750 x 520 x 55mm Cut Out Dimensions (WxDxH): 560 x 490mm 1 x WOK burner: 3800 W 1 x Rapid burner: 2900 W 2 x Semi-rapid burner: 1750 W 1 x Auxiliary burner: 1000 W Maximum Power: 11200 W Gas Type: NG NG/LPG Options

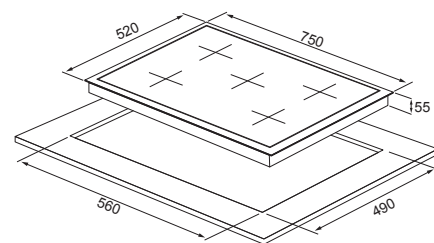

MyFlame

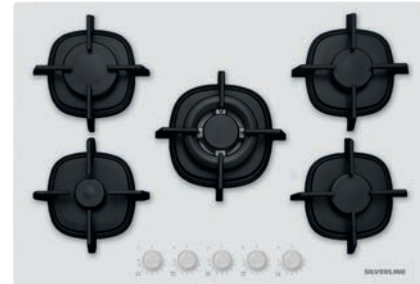

## CS5426W01

<b>Hob Features</b>	Built-in 75cm White
<b>Comfort Features</b>	Cast Iron Pan Supports 4 Gas Burners 1 WOK Auto Ignition Front Mechanical Control MY FLAME
<b>Safety</b>	Gas Safety Device
<b>Other Features</b>	Product Dimensions (WxDxH): 750 x 520 x 55mm Cut Out Dimensions (WxDxH): 560 x 490mm 1 x WOK burner: 3800 W 1 x Rapid burner: 2900 W 2 x Semi-rapid burner: 1750 W 1 x Auxiliary burner: 1000 W Maximum Power: 11200 W Gas Type: NG NG/LPG Options

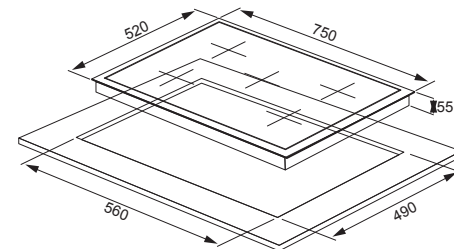

MyFlame

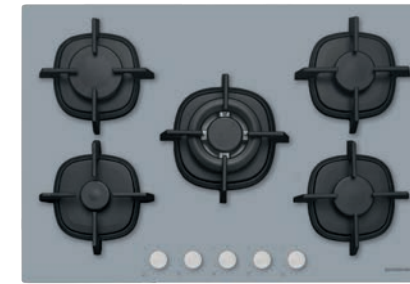

## CS5426S01

<b>Hob Features</b>	Built-in 75cm Grey
<b>Comfort Features</b>	Enamel Pan Supports 4 Gas Burners 1 WOK Auto Ignition Front Mechanical Control MY FLAME
<b>Safety</b>	Gas Safety Device
<b>Other Features</b>	Product Dimensions (WxDxH): 750 x 520 x 55mm Cut Out Dimensions (WxDxH): 560 x 490mm 1 x WOK burner: 3800 W 1 x Rapid burner: 2900 W 2 x Semi-rapid burner: 1750 W 1 x Auxiliary burner: 1000 W Maximum Power: 11200 W Gas Type: NG NG/LPG Options

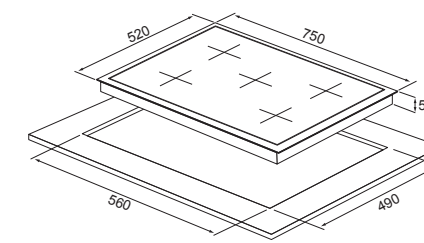

MyFlame

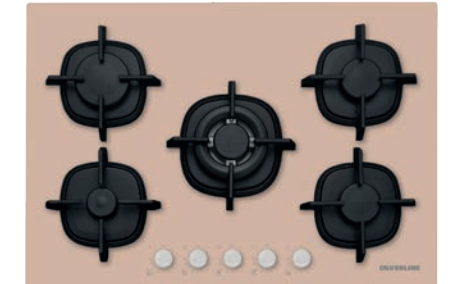

## CS5426M01

<b>Hob Features</b>	Built-in 75cm Mink
<b>Comfort Features</b>	Enamel Pan Supports 4 Gas Burners 1 WOK Auto Ignition Front Mechanical Control
<b>Safety</b>	Gas Safety Device
<b>Other Features</b>	Product Dimensions (WxDxH): 750 x 520 x 55mm Cut Out Dimensions (WxDxH): 560 x 490mm 1 x WOK burner: 3800 W 1 x Rapid burner: 2900 W 2 x Semi-rapid burner: 1750 W 1 x Auxiliary burner: 1000 W Maximum Power: 11200 W Gas Type: NG NG/LPG Options

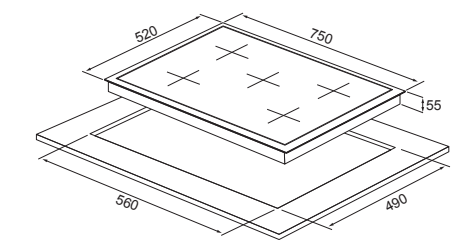

# GLASS BUILT-IN HOBS

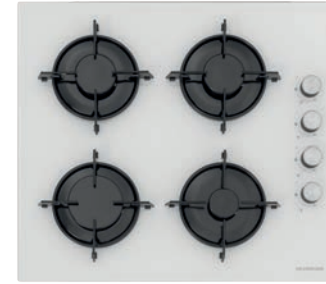

## CS5349B01

<b>Hob Features</b>	Built-in 60cm Black
<b>Comfort Features</b>	Enamel Pan Supports 4 Gas Burners Auto Ignition Side Mechanical Control
<b>Safety</b>	Gas Safety Device
<b>Other Features</b>	Product Dimensions (WxDxH): 590 x 520 x 55mm Cut Out Dimensions (WxDxH): 560 x 490mm 1 x Rapid burner: 2900 W 2 x Semi-rapid burner: 1750 W 1 x Auxiliary burner: 1000 W Maximum Power: 7400 W Gas Type: NG NG/LPG Options

## CS5392B01

<b>Hob Features</b>	Built-in 60cm Black
<b>Comfort Features</b>	Enamel Pan Supports 3 Gas Burners 1 Electric Burner Auto Ignition Side Mechanical Control
<b>Safety</b>	Gas Safety Device
<b>Other Features</b>	Product Dimensions (WxDxH): 590 x 520 x 55mm Cut Out Dimensions (WxDxH): 880 x 660 x 150mm 1 x Rapid burner: 2900 W 1 x Semi-rapid burner: 1750 W 1 x Electric rapid burner: 1500 W 1 x Auxiliary burner: 1000 W Maximum Power: 1200 W Gas Type: NG

## CS5408B01

<b>Hob Features</b>	Built-in 60cm Black
<b>Comfort Features</b>	Enamel Pan Supports 3 Gas Burners 1 WOK Burners Auto Ignition Under Mechanical Control
<b>Safety</b>	Gas Safety Device
<b>Other Features</b>	Product Dimensions (WxDxH): 590 x 520 x 55mm Cut Out Dimensions (WxDxH): 560 x 490mm 1 x WOK burner: 3600 W 2 x Semi-rapid burner: 1750 W 1 x Auxiliary burner: 1000 W Maximum Power: 1200 W Gas Type: NG NG/LPG Options

## CS5349W01

<b>Hob Features</b>	Built-in 60cm White
<b>Comfort Features</b>	Enamel Pan Supports 4 Gas Burners Auto Ignition Side Mechanical Control
<b>Safety</b>	Gas Safety Device
<b>Other Features</b>	Product Dimensions (WxDxH): 590 x 520 x 55mm Cut Out Dimensions (WxDxH): 560 x 490mm 1 x Rapid burner: 2900 W 2 x Semi-rapid burner: 1750 W 1 x Auxiliary burner: 1000 W Maximum Power: 7400 W Gas Type: NG NG/LPG Options

## CS5392W01

<b>Hob Features</b>	Built-in 60cm Black
<b>Comfort Features</b>	Enamel Pan Supports 3 Gas Burners 1 Electric Burner Auto Ignition Side Mechanical Control
<b>Safety</b>	Gas Safety Device
<b>Other Features</b>	Product Dimensions (WxDxH): 590 x 520 x 55mm Cut Out Dimensions (WxDxH): 880 x 660 x 150mm 1 x Rapid burner: 2900 W 1 x Semi-rapid burner: 1750 W 1 x Electric rapid burner: 1500 W 1 x Auxiliary burner: 1000 W Maximum Power: 1200 W Gas Type: NG

## CS5408W01

<b>Hob Features</b>	Built-in 60cm White
<b>Comfort Features</b>	Enamel Pan Supports 3 Gas Burners 1 WOK Burners Auto Ignition Under Mechanical Control
<b>Safety</b>	Gas Safety Device
<b>Other Features</b>	Product Dimensions (WxDxH): 590 x 520 x 55mm Cut Out Dimensions (WxDxH): 560 x 490mm 1 x WOK burner: 3600 W 2 x Semi-rapid burner: 1750 W 1 x Auxiliary burner: 1000 W Maximum Power: 1200 W Gas Type: NG NG/LPG Options

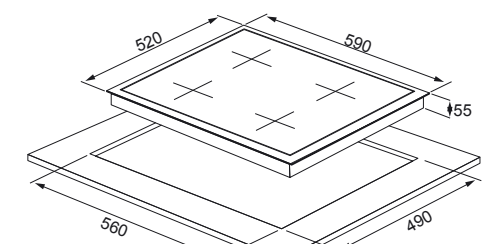
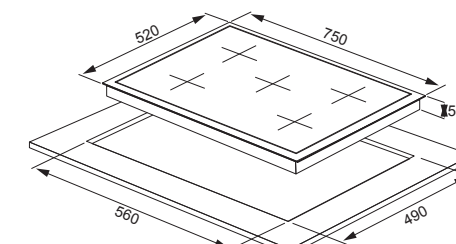
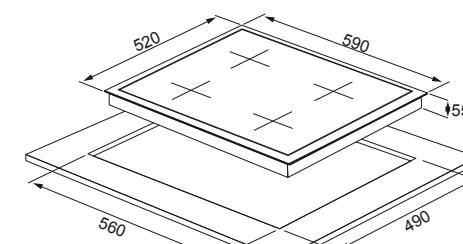
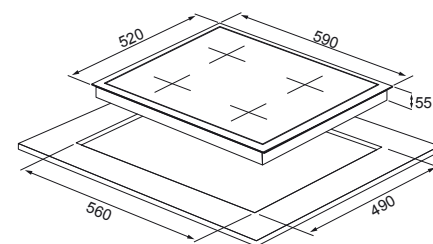
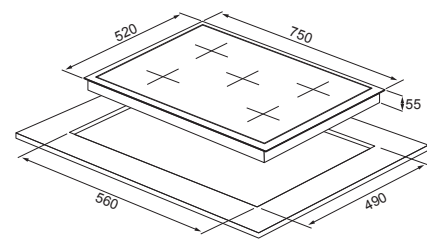
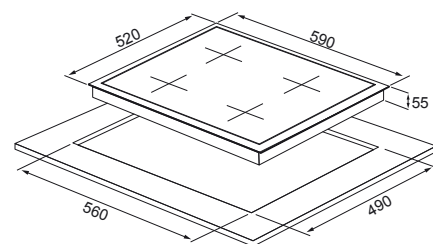

# GLASS BUILT-IN HOBS

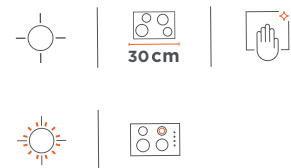

## CS5410B01

<b>Hob Features</b>	Built-in 30cm Black
<b>Comfort Features</b>	Cast Iron Pans Supports 2 Gas Burners Auto Ignition Front Mechanical Control
<b>Safety</b>	Gas Safety Device
<b>Other Features</b>	Product Dimensions (WxDxH): 300 x 520 x 55mm Cut Out Dimensions (WxDxH): 260 x 490mm 1 x Semi-rapid burner: 1750 W 1 x Auxiliary burner: 1000 W Maximum Power: 2750 W Gas Type: NG NG/LPG Options

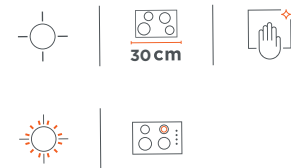
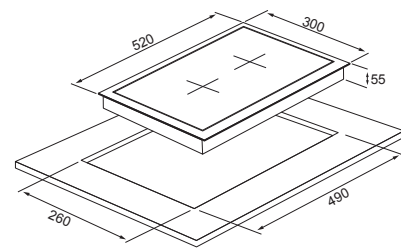

## CS5411B01

<b>Hob Features</b>	Built-in 30cm Black
<b>Comfort Features</b>	Cast Iron Pans Supports 1 WOK Auto Ignition Front Mechanical Control
<b>Safety</b>	Gas Safety Device
<b>Other Features</b>	Product Dimensions (WxDxH): 300 x 520 x 55mm Cut Out Dimensions (WxDxH): 260 x 490mm 1 x WOK burner: 3800 W Maximum Power: 3800 W Gas Type: NG NG/LPG Options

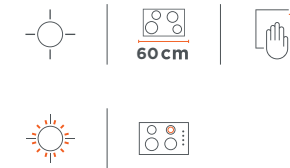
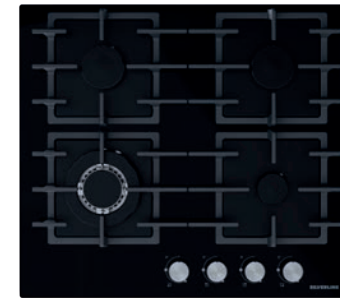
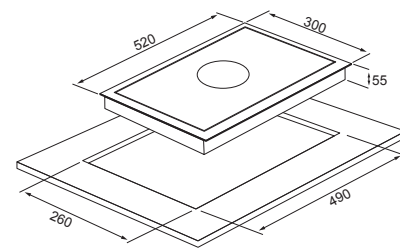

## CS5409B01

<b>Hob Features</b>	Built-in 60cm Black
<b>Comfort Features</b>	Cast Grill 3 Gas Burners 1 WOK Burners Auto Ignition Under Mechanical Control
<b>Safety</b>	Gas Safety Device
<b>Other Features</b>	Product Dimensions (WxDxH): 590 x 520 x 55mm Cut Out Dimensions (WxDxH): 560 x 490mm 1 x WOK burner: 3600 W 2 x Semi-rapid burner: 1750 W 1 x Auxiliary burner: 1000 W Maximum Power: 1200 W Gas Type: NG NG/LPG Options

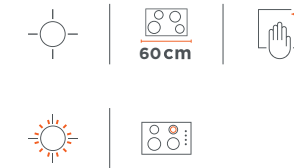
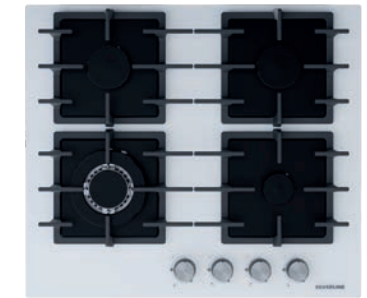
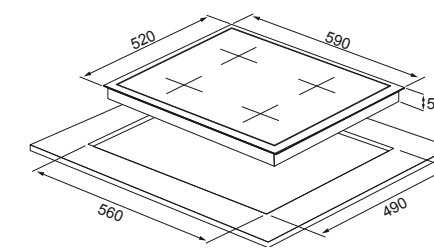

## CS5409W01

<b>Hob Features</b>	Built-in 60cm White
<b>Comfort Features</b>	Cast Grill 3 Gas Burners 1 WOK Burners Auto Ignition Under Mechanical Control
<b>Safety</b>	Gas Safety Device
<b>Other Features</b>	Product Dimensions (WxDxH): 590 x 520 x 55mm Cut Out Dimensions (WxDxH): 560 x 490mm 1 x WOK burner: 3600 W 2 x Semi-rapid burner: 1750 W 1 x Auxiliary burner: 1000 W Maximum Power: 1200 W Gas Type: NG NG/LPG Options

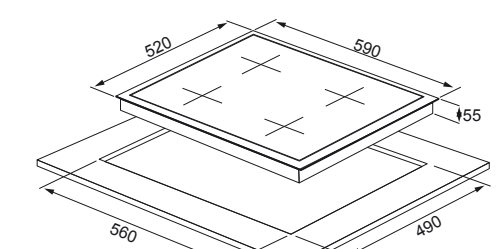



# GLASS BUILT-IN HOBS

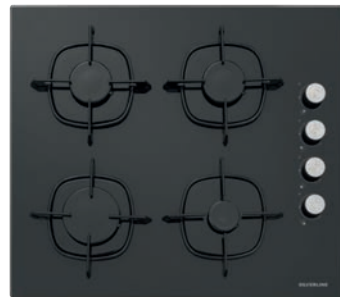

## CS5335B01

- Hob Features** Built-in  
60cm  
Black
- Comfort Features** Enamel Pan Supports  
4 Gas Burners  
Auto Ignition  
Side Mechanical Control
- Safety** Gas Safety Device
- Other Features** Product Dimensions (WxDxH):  
590 x 520 x 55mm  
Cut Out Dimensions (WxDxH):  
560 x 490mm  
1 x Rapid burner: 2900 W  
2 x Semi-rapid burner: 1750 W  
1 x Auxiliary burner: 1000 W  
Maximum Power: 7400 W  
Gas Type: NG  
NG/LPG Options

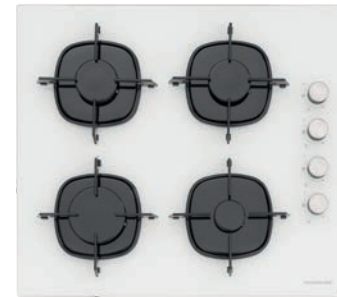
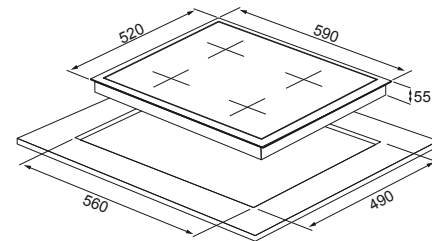

## CS5335W01

- Hob Features** Built-in  
60cm  
White
- Comfort Features** Enamel Pan Supports  
4 Gas Burners  
Auto Ignition  
Side Mechanical Control
- Safety** Gas Safety Device
- Other Features** Product Dimensions (WxDxH):  
590 x 520 x 55mm  
Cut Out Dimensions (WxDxH):  
560 x 490mm  
1 x Rapid burner: 2900 W  
2 x Semi-rapid burner: 1750 W  
1 x Auxiliary burner: 1000 W  
Maximum Power: 7400 W  
Gas Type: NG  
NG/LPG Options

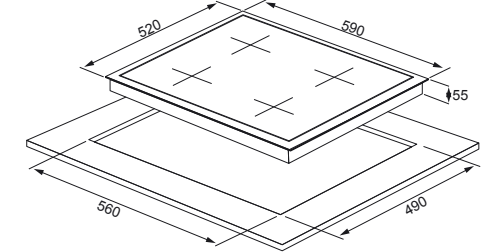

## CS5343B01

- Hob Features** Built-in  
60cm  
Black
- Comfort Features** Cast Iron Pans Supports  
4 Gas Burners  
Auto Ignition  
Side Mechanical Control
- Safety** Gas Safety Device
- Other Features** Product Dimensions (WxDxH):  
590 x 520 x 55mm  
Cut Out Dimensions (WxDxH):  
560 x 490mm  
1 x Rapid burner: 2900 W  
2 x Semi-rapid burner: 1750 W  
1 x Auxiliary burner: 1000 W  
Maximum Power: 7400 W  
Gas Type: NG  
NG/LPG Options

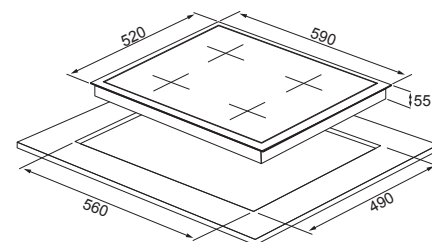

## CS5343W01

- Hob Features** Built-in  
60cm  
White
- Comfort Features** Cast Iron Pans Supports  
4 Gas Burners  
Auto Ignition  
Side Mechanical Control
- Safety** Gas Safety Device
- Other Features** Product Dimensions (WxDxH):  
590 x 520 x 55mm  
Cut Out Dimensions (WxDxH):  
560 x 490mm  
1 x Rapid burner: 2900 W  
2 x Semi-rapid burner: 1750 W  
1 x Auxiliary burner: 1000 W  
Maximum Power: 7400 W  
Gas Type: NG  
NG/LPG Options

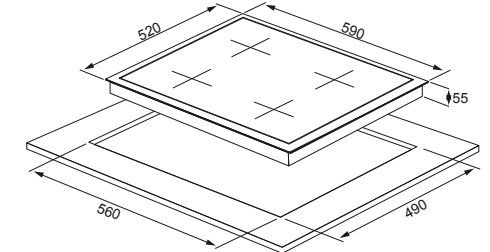

# GLASS BUILT-IN HOBS

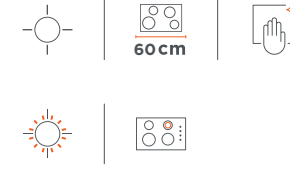
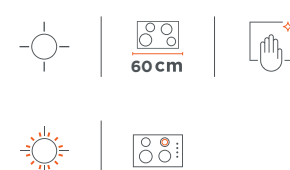
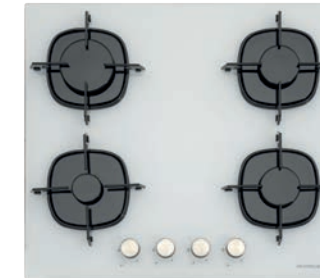
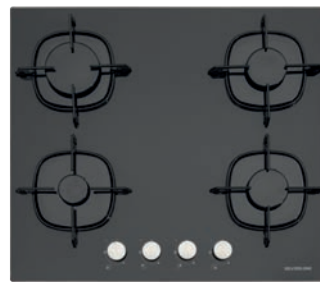

## CS5430B01

<b>Hob Features</b>	Built-in 60cm Black
<b>Comfort Features</b>	Cast Iron Pans Supports 3 Gas Burners 1 Hot Plate Auto Ignition Side Mechanical Control
<b>Safety</b>	Gas Safety Device
<b>Other Features</b>	Product Dimensions (WxDxH): 590 x 520 x 55mm Cut Out Dimensions (WxDxH): 560 x 490mm 1 x Rapid burner: 2900 W 1 x Semi-rapid burner: 1750 W 1 x Auxiliary burner: 1000 W Rear Right Zone Size / Power: 145 / 1500W Maximum Power: 7150 W Gas Type: NG NG/LPG Options

## CS5436B01

<b>Hob Features</b>	Built-in 60cm Black
<b>Comfort Features</b>	Enamel Pan Supports 4 Gas Burners Auto Ignition Front Mechanical Control
<b>Safety</b>	Gas Safety Device
<b>Other Features</b>	Product Dimensions (WxDxH): 590 x 520 x 55mm Cut Out Dimensions (WxDxH): 560 x 490mm 1 x Rapid burner: 2900 W 2 x Semi-rapid burner: 1750 W 1 x Auxiliary burner: 1000 W Maximum Power: 7400 W Gas Type: NG NG/LPG Options

## CS5429B01

<b>Hob Features</b>	Built-in 60cm Black
<b>Comfort Features</b>	Cast Iron Pans Supports 3 Gas Burners 1 WOK Auto Ignition Side Mechanical Control
<b>Safety</b>	Gas Safety Device
<b>Other Features</b>	Product Dimensions (WxDxH): 590 x 520 x 55mm Cut Out Dimensions (WxDxH): 560 x 490mm 1 x WOK burner: 3800 W 2 x Semi-rapid burner: 1750 W 1 x Auxiliary burner: 1000 W Maximum Power: 8300 W Gas Type: NG NG/LPG Options

## CS5430W01

<b>Hob Features</b>	Built-in 60cm White
<b>Comfort Features</b>	Cast Iron Pans Supports 3 Gas Burners 1 Hot Plate Auto Ignition Side Mechanical Control
<b>Safety</b>	Gas Safety Device
<b>Other Features</b>	Product Dimensions (WxDxH): 590 x 520 x 55mm Cut Out Dimensions (WxDxH): 560 x 490mm 1 x Rapid burner: 2900 W 1 x Semi-rapid burner: 1750 W 1 x Auxiliary burner: 1000 W Rear Right Zone Size / Power: 145 / 1500W Maximum Power: 7150 W Gas Type: NG NG/LPG Options

## CS5436W01

<b>Hob Features</b>	Built-in 60cm White
<b>Comfort Features</b>	Enamel Pan Supports 4 Gas Burners Auto Ignition Front Mechanical Control
<b>Safety</b>	Gas Safety Device
<b>Other Features</b>	Product Dimensions (WxDxH): 590 x 520 x 55mm Cut Out Dimensions (WxDxH): 560 x 490mm 1 x Rapid burner: 2900 W 2 x Semi-rapid burner: 1750 W 1 x Auxiliary burner: 1000 W Maximum Power: 7400 W Gas Type: NG NG/LPG Options

## CS5429W01

<b>Hob Features</b>	Built-in 60cm White
<b>Comfort Features</b>	Cast Iron Pans Supports 3 Gas Burners 1 WOK Auto Ignition Side Mechanical Control
<b>Safety</b>	Gas Safety Device
<b>Other Features</b>	Product Dimensions (WxDxH): 590 x 520 x 55mm Cut Out Dimensions (WxDxH): 560 x 490mm 1 x WOK burner: 3800 W 2 x Semi-rapid burner: 1750 W 1 x Auxiliary burner: 1000 W Maximum Power: 8300 W Gas Type: NG NG/LPG Options

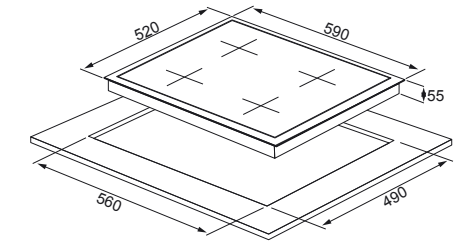
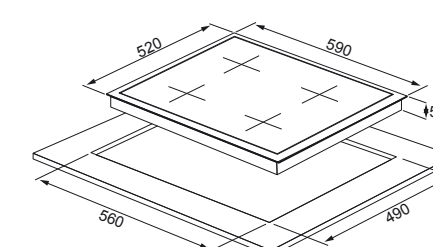
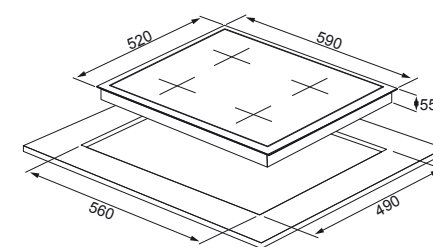
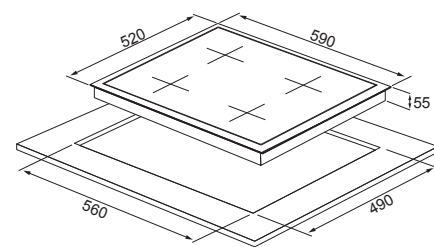
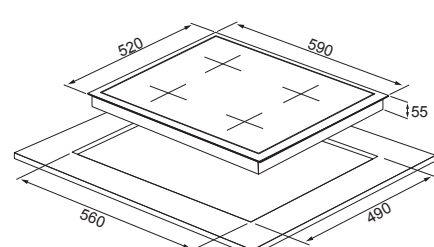
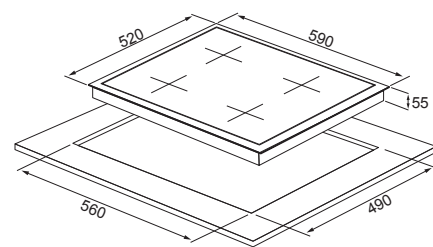

# GLASS BUILT-IN HOBS



## CS5407B01

- Hob Features** Built-in  
60cm  
Black
- Comfort Features** Cast Iron Pans Supports  
3 Gas Burners 1 WOK  
Auto Ignition  
Front Mechanical Control
- Safety** Gas Safety Device
- Other Features** Product Dimensions (WxDxH):  
590 x 520 x 55mm  
Cut Out Dimensions (WxDxH):  
560 x 490mm  
1 x WOK burner: 3800 W  
2 x Semi-rapid burner: 1750 W  
1 x Auxiliary burner: 1000 W  
Maximum Power: 8300 W  
Gas Type: NG  
NG/LPG Options

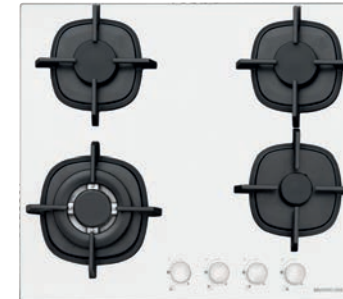
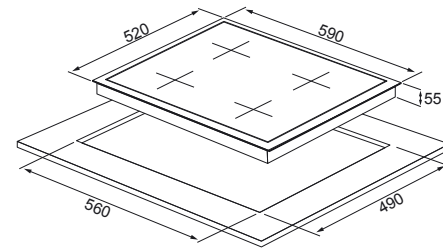

## CS5407W01

- Hob Features** Built-in  
60cm  
White
- Comfort Features** Cast Iron Pans Supports  
3 Gas Burners 1 WOK  
Auto Ignition  
Front Mechanical Control
- Safety** Gas Safety Device
- Other Features** Product Dimensions (WxDxH):  
590 x 520 x 55mm  
Cut Out Dimensions (WxDxH):  
560 x 490mm  
1 x WOK burner: 3800 W  
2 x Semi-rapid burner: 1750 W  
1 x Auxiliary burner: 1000 W  
Maximum Power: 8300 W  
Gas Type: NG  
NG/LPG Options

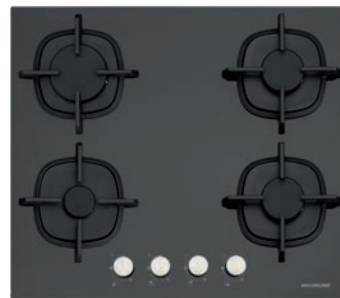
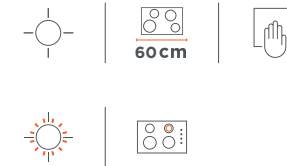
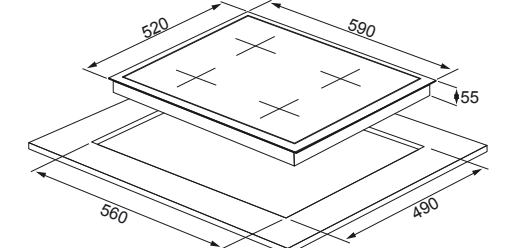

## CS5437B01

- Hob Features** Built-in  
60cm  
Black
- Comfort Features** Cast Iron Pans Supports  
4 Gas Burners  
Auto Ignition  
Front Mechanical Control
- Safety** Gas Safety Device
- Other Features** Product Dimensions (WxDxH):  
590 x 520 x 55mm  
Cut Out Dimensions (WxDxH):  
560 x 490mm  
1 x Rapid burner: 2900 W  
2 x Semi-rapid burner: 1750 W  
1 x Auxiliary burner: 1000 W  
Maximum Power: 7400 W  
Gas Type: NG  
NG/LPG Options

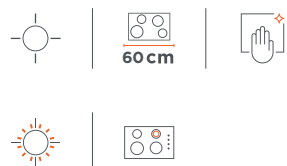
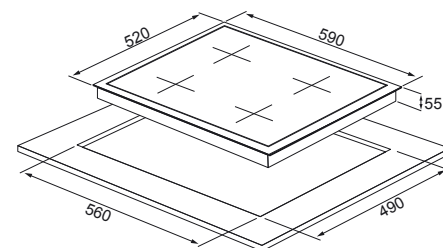

## CS5437W01

- Hob Features** Built-in  
60cm  
White
- Comfort Features** Cast Iron Pans Supports  
4 Gas Burners  
Auto Ignition  
Front Mechanical Control
- Safety** Gas Safety Device
- Other Features** Product Dimensions (WxDxH):  
590 x 520 x 55mm  
Cut Out Dimensions (WxDxH):  
560 x 490mm  
1 x Rapid burner: 2900 W  
2 x Semi-rapid burner: 1750 W  
1 x Auxiliary burner: 1000 W  
Maximum Power: 7400 W  
Gas Type: NG  
NG/LPG Options

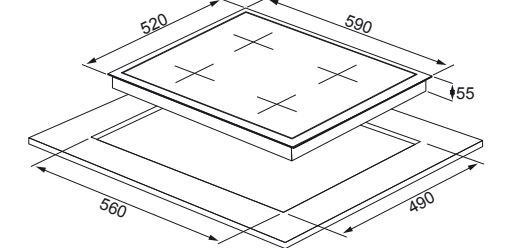

# GLASS BUILT-IN HOBS

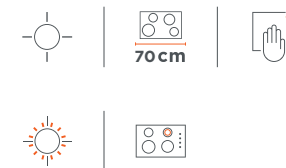
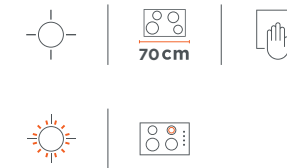
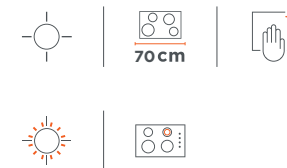
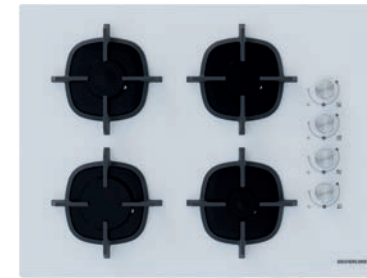
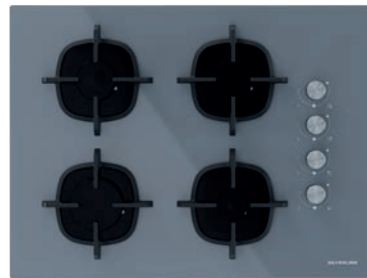
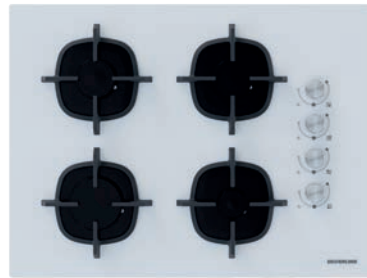

## CS5665W01

<b>Hob Features</b>	Built-in 65cm White
<b>Comfort Features</b>	Enamel Pans Supports 4 Gas Burners Auto Ignition Side Mechanical Control
<b>Safety</b>	Gas Safety Device
<b>Other Features</b>	Product Dimensions (WxDxH): 690 x 520 x 55mm Cut Out Dimensions (WxDxH): 830 x 490mm 1 x Rapid burner: 2900 W 2 x Semi-rapid burner: 1750 W 1 x Auxiliary burner: 1000 W Maximum Power: 7400 W Gas Type: NG NG/LPG Options

## CS5665B01

<b>Hob Features</b>	Built-in 65cm Black
<b>Comfort Features</b>	Enamel Pans Supports 4 Gas Burners Auto Ignition Side Mechanical Control
<b>Safety</b>	Gas Safety Device
<b>Other Features</b>	Product Dimensions (WxDxH): 690 x 520 x 55mm Cut Out Dimensions (WxDxH): 830 x 490mm 1 x Rapid burner: 2900 W 2 x Semi-rapid burner: 1750 W 1 x Auxiliary burner: 1000 W Maximum Power: 7400 W Gas Type: NG NG/LPG Options

## CS5665S01

<b>Hob Features</b>	Built-in 65cm Silver
<b>Comfort Features</b>	Enamel Pans Supports 4 Gas Burners Auto Ignition Side Mechanical Control
<b>Safety</b>	Gas Safety Device
<b>Other Features</b>	Product Dimensions (WxDxH): 690 x 520 x 55mm Cut Out Dimensions (WxDxH): 830 x 490mm 1 x Rapid burner: 2900 W 2 x Semi-rapid burner: 1750 W 1 x Auxiliary burner: 1000 W Maximum Power: 7400 W Gas Type: NG NG/LPG Options

## CS5666W01

<b>Hob Features</b>	Built-in 65cm White
<b>Comfort Features</b>	Cast Iron Pans Supports 4 Gas Burners Auto Ignition Side Mechanical Control
<b>Safety</b>	Gas Safety Device
<b>Other Features</b>	Product Dimensions (WxDxH): 690 x 520 x 55mm Cut Out Dimensions (WxDxH): 830 x 490mm 1 x Rapid burner: 2900 W 2 x Semi-rapid burner: 1750 W 1 x Auxiliary burner: 1000 W Maximum Power: 7400 W Gas Type: NG NG/LPG Options

## CS5666B01

<b>Hob Features</b>	Built-in 65cm Black
<b>Comfort Features</b>	Cast Iron Pans Supports 4 Gas Burners Auto Ignition Side Mechanical Control
<b>Safety</b>	Gas Safety Device
<b>Other Features</b>	Product Dimensions (WxDxH): 690 x 520 x 55mm Cut Out Dimensions (WxDxH): 830 x 490mm 1 x Rapid burner: 2900 W 2 x Semi-rapid burner: 1750 W 1 x Auxiliary burner: 1000 W Maximum Power: 7400 W Gas Type: NG NG/LPG Options

## CS5666S01

<b>Hob Features</b>	Built-in 65cm Silver
<b>Comfort Features</b>	Cast Iron Pans Supports 4 Gas Burners Auto Ignition Side Mechanical Control
<b>Safety</b>	Gas Safety Device
<b>Other Features</b>	Product Dimensions (WxDxH): 690 x 520 x 55mm Cut Out Dimensions (WxDxH): 830 x 490mm 1 x Rapid burner: 2900 W 2 x Semi-rapid burner: 1750 W 1 x Auxiliary burner: 1000 W Maximum Power: 7400 W Gas Type: NG NG/LPG Options

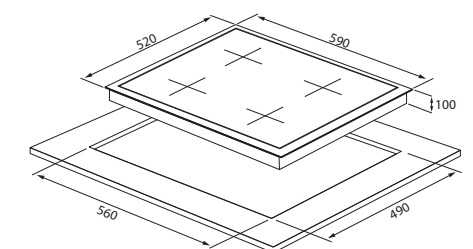
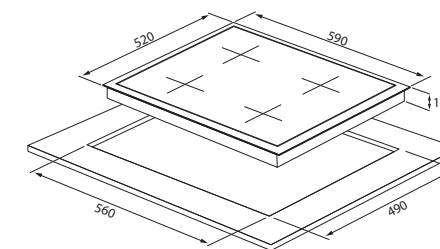
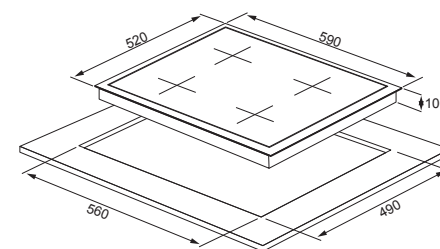
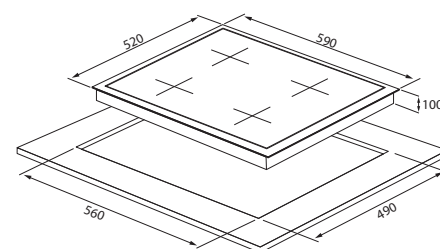
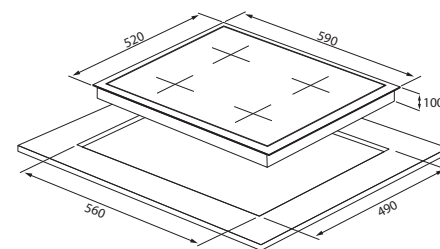
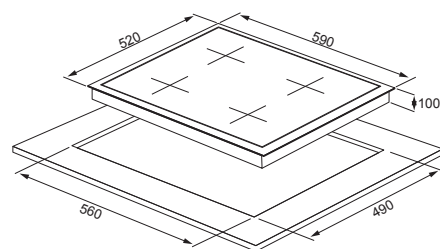

# GLASS BUILT-IN HOBS

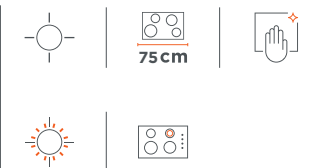
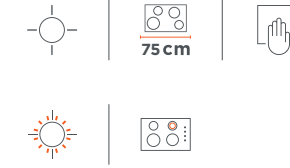
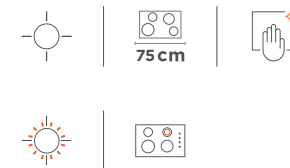
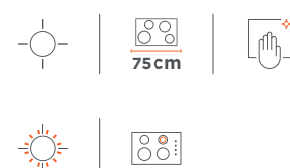
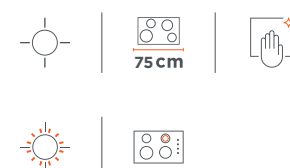
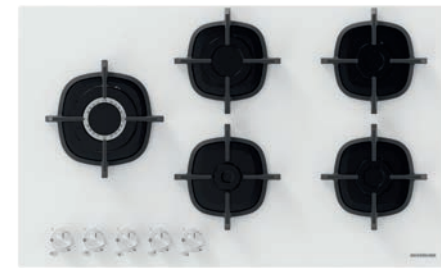
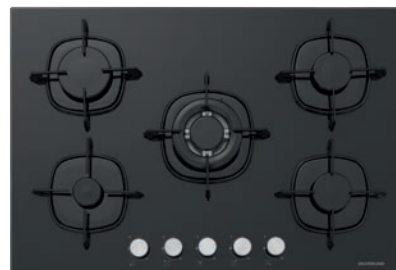
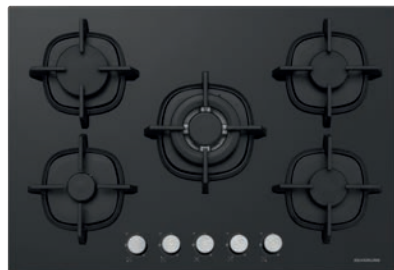
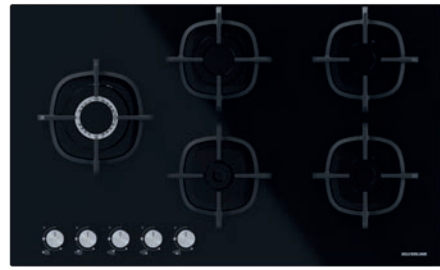

## CS5613B01

<b>Hob Features</b>	Built-in 75cm Black
<b>Comfort Features</b>	Enamel Pan Supports 4 Gas Burners 1 WOK Auto Ignition Front Mechanical Control
<b>Safety</b>	Gas Safety Device
<b>Other Features</b>	Product Dimensions (WxDxH): 750 x 520 x 55mm Cut Out Dimensions (WxDxH): 560 x 490mm 1 x WOK burner: 3800 W 1 x Rapid burner: 2900 W 2 x Semi-rapid burner: 1750 W 1 x Auxiliary burner: 1000 W Maximum Power: 11200 W Gas Type: NG NG/LPG Options

## CS5364B01

<b>Hob Features</b>	Built-in 75cm Black
<b>Comfort Features</b>	Cast Iron Pans Supports 4 Gas Burners 1 WOK Auto Ignition Front Mechanical Control
<b>Safety</b>	Gas Safety Device
<b>Other Features</b>	Product Dimensions (WxDxH): 750 x 520 x 55mm Cut Out Dimensions (WxDxH): 560 x 490mm 1 x WOK burner: 3800 W 1 x Rapid burner: 2900 W 2 x Semi-rapid burner: 1750 W 1 x Auxiliary burner: 1000 W Maximum Power: 11200 W Gas Type: NG NG/LPG Options

## CS5365B01

<b>Hob Features</b>	Built-in 75cm Black
<b>Comfort Features</b>	Enamel Pan Supports 4 Gas Burners 1 WOK Auto Ignition Front Mechanical Control
<b>Safety</b>	Gas Safety Device
<b>Other Features</b>	Product Dimensions (WxDxH): 750 x 520 x 55mm Cut Out Dimensions (WxDxH): 560 x 490mm 1 x WOK burner: 3800 W 1 x Rapid burner: 2900 W 2 x Semi-rapid burner: 1750 W 1 x Auxiliary burner: 1000 W Maximum Power: 11200 W Gas Type: NG NG/LPG Options

## CS5613W01

<b>Hob Features</b>	Built-in 75cm White
<b>Comfort Features</b>	Enamel Pan Supports 4 Gas Burners 1 WOK Auto Ignition Front Mechanical Control
<b>Safety</b>	Gas Safety Device
<b>Other Features</b>	Product Dimensions (WxDxH): 750 x 520 x 55mm Cut Out Dimensions (WxDxH): 560 x 490mm 1 x WOK burner: 3800 W 1 x Rapid burner: 2900 W 2 x Semi-rapid burner: 1750 W 1 x Auxiliary burner: 1000 W Maximum Power: 11200 W Gas Type: NG NG/LPG Options

## CS5364W01

<b>Hob Features</b>	Built-in 75cm White
<b>Comfort Features</b>	Cast Iron Pans Supports 4 Gas Burners 1 WOK Auto Ignition Front Mechanical Control
<b>Safety</b>	Gas Safety Device
<b>Other Features</b>	Product Dimensions (WxDxH): 750 x 520 x 55mm Cut Out Dimensions (WxDxH): 560 x 490mm 1 x WOK burner: 3800 W 1 x Rapid burner: 2900 W 2 x Semi-rapid burner: 1750 W 1 x Auxiliary burner: 1000 W Maximum Power: 11200 W Gas Type: NG NG/LPG Options

## CS5365W01

<b>Hob Features</b>	Built-in 75cm White
<b>Comfort Features</b>	Enamel Pan Supports 4 Gas Burners 1 WOK Auto Ignition Front Mechanical Control
<b>Safety</b>	Gas Safety Device
<b>Other Features</b>	Product Dimensions (WxDxH): 750 x 520 x 55mm Cut Out Dimensions (WxDxH): 560 x 490mm 1 x WOK burner: 3800 W 1 x Rapid burner: 2900 W 2 x Semi-rapid burner: 1750 W 1 x Auxiliary burner: 1000 W Maximum Power: 11200 W Gas Type: NG NG/LPG Options

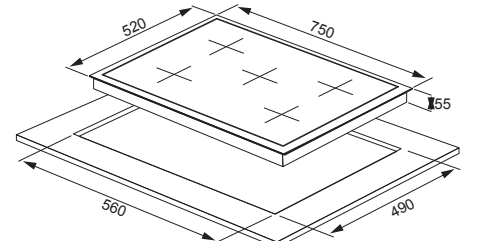
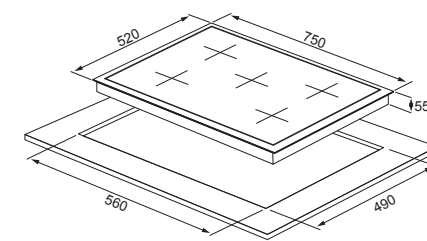
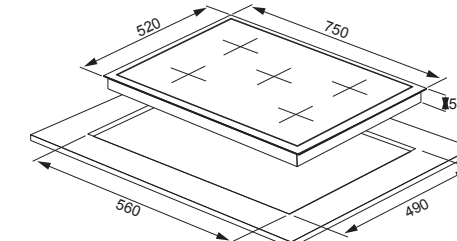
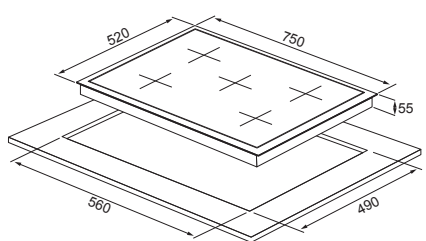
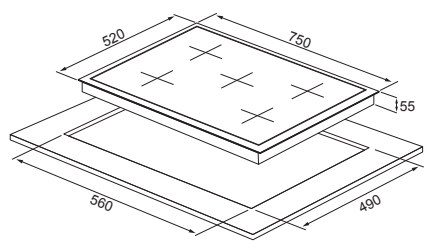
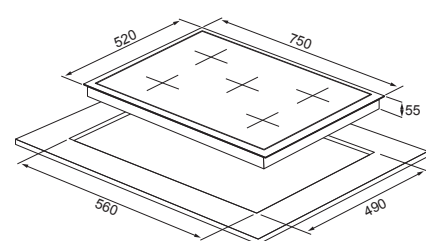

# GLASS BUILT-IN HOBS



## CS5363W01

<b>Hob Features</b>	Built-in 90cm White
<b>Comfort Features</b>	Cast Iron Pans Supports 4 Gas Burners 1 WOK Auto Ignition Front Mechanical Control
<b>Safety</b>	Gas Safety Device
<b>Other Features</b>	Product Dimensions (WxDxH): 860 x 520 x 55mm Cut Out Dimensions (WxDxH): 830x490mm 1 x WOK burner: 3800 W 1 x Rapid burner: 2900 W 2 x Semi-rapid burner: 1750 W 1 x Auxiliary burner: 1000 W Maximum Power: 11200 W Gas Type: NG NG/LPG Options

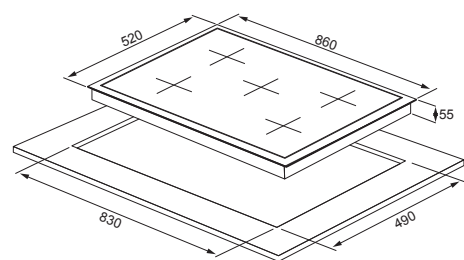

## CS5363B01

<b>Hob Features</b>	Built-in 90cm Black
<b>Comfort Features</b>	Cast Iron Pans Supports 4 Gas Burners 1 WOK Auto Ignition Front Mechanical Control
<b>Safety</b>	Gas Safety Device
<b>Other Features</b>	Product Dimensions (WxDxH): 860 x 520 x 55mm Cut Out Dimensions (WxDxH): 830 x 490mm 1 x WOK burner: 3800 W 1 x Rapid burner: 2900 W 2 x Semi-rapid burner: 1750 W 1 x Auxiliary burner: 1000 W Maximum Power: 11200 W Gas Type: NG NG/LPG Options

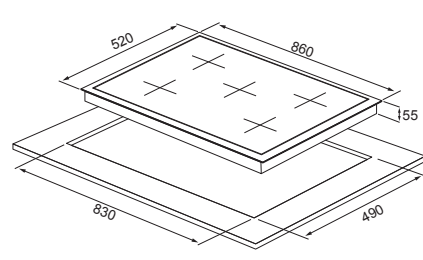

## CS5614B01

<b>Hob Features</b>	Built-in 90cm Black
<b>Comfort Features</b>	Cast Iron Supports 4 Gas Burners 1 WOK Auto Ignition Front Mechanical Control
<b>Safety</b>	Gas Safety Device
<b>Other Features</b>	Product Dimensions (WxDxH): 750 x 520 x 55mm Cut Out Dimensions (WxDxH): 880 x 660 x 150mm 1 x WOK burner: 3800 W 1 x Rapid burner: 2900 W 2 x Semi-rapid burner: 1750 W 1 x Auxiliary burner: 1000 W Maximum Power: 11200 W Gas Type: NG NG/LPG Options

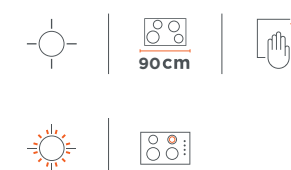
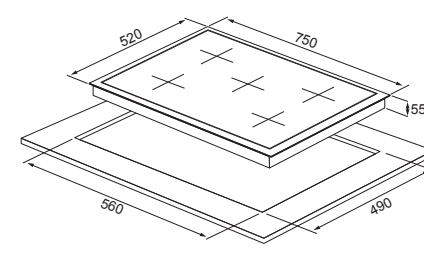

## CS5614W01

<b>Hob Features</b>	Built-in 90cm White
<b>Comfort Features</b>	Cast Iron Supports Supports 4 Gas Burners 1 WOK Auto Ignition Front Mechanical Control
<b>Safety</b>	Gas Safety Device
<b>Other Features</b>	Product Dimensions (WxDxH): 750 x 520 x 55mm Cut Out Dimensions (WxDxH): 880 x 660 x 150mm 1 x WOK burner: 3800 W 1 x Rapid burner: 2900 W 2 x Semi-rapid burner: 1750 W 1 x Auxiliary burner: 1000 W Maximum Power: 11200 W Gas Type: NG NG/LPG Options

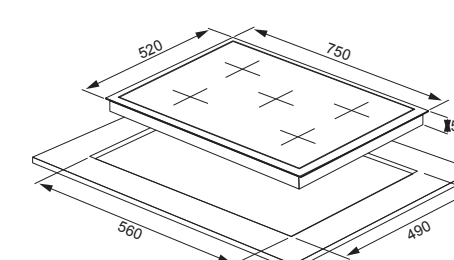

# GLASS BUILT-IN HOBS

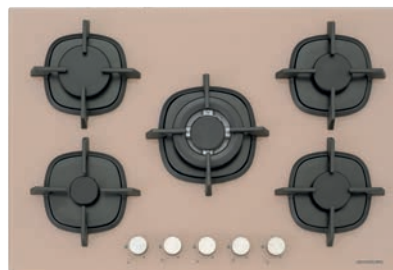
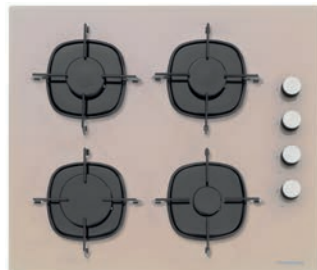

## CS5343M01

<b>Hob Features</b>	Built-in 60cm Mink
<b>Comfort Features</b>	Cast Iron Pans Supports 4 Gas Burners Auto Ignition Side Mechanical Control
<b>Safety</b>	Gas Safety Device
<b>Other Features</b>	Product Dimensions (WxDxH): 590 x 520 x 55mm Cut Out Dimensions (WxDxH): 560 x 490mm 1 x Rapid burner: 2900 W 2 x Semi-rapid burner: 1750 W 1 x Auxiliary burner: 1000 W Maximum Power: 7400 W Gas Type: NG NG/LPG Options

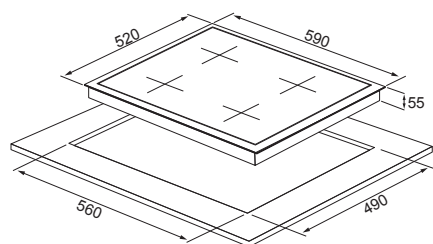

## CS5335M01

<b>Hob Features</b>	Built-in 60cm Mink
<b>Comfort Features</b>	Enamel Pan Supports 4 Gas Burners Auto Ignition Side Mechanical Control
<b>Safety</b>	Gas Safety Device
<b>Other Features</b>	Product Dimensions (WxDxH): 590 x 520 x 55mm Cut Out Dimensions (WxDxH): 560 x 490mm 1 x Rapid burner: 2900 W 2 x Semi-rapid burner: 1750 W 1 x Auxiliary burner: 1000 W Maximum Power: 7400 W Gas Type: NG NG/LPG Options

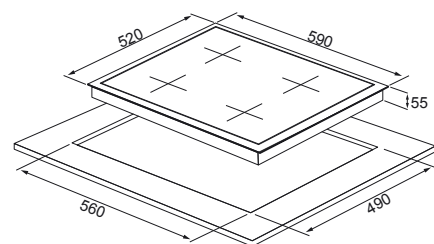

## CS5364M01

<b>Hob Features</b>	Built-in 75cm Mink
<b>Comfort Features</b>	Cast Iron Pans Supports 4 Gas Burners 1 WOK Auto Ignition Front Mechanical Control
<b>Safety</b>	Gas Safety Device
<b>Other Features</b>	Product Dimensions (WxDxH): 750 x 520 x 55mm Cut Out Dimensions (WxDxH): 560 x 490mm 1x WOK burner: 3800 W 1 x Rapid burner: 2900 W 2 x Semi-rapid burner: 1750 W 1 x Auxiliary burner: 1000 W Maximum Power: 11200 W Gas Type: NG NG/LPG Options

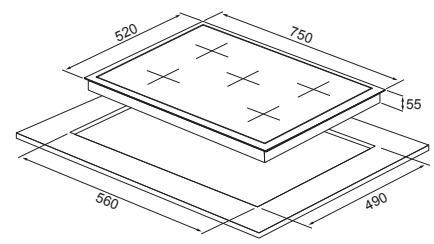

# GLASS BUILT-IN HOBS

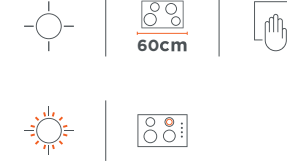
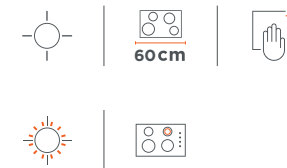
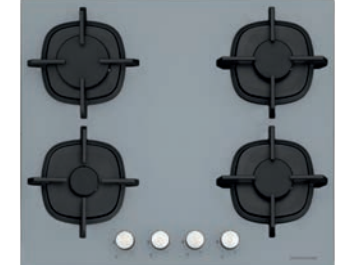
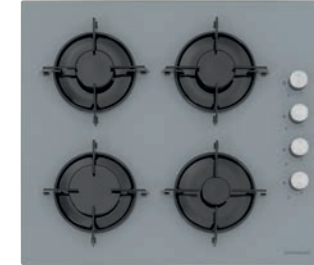
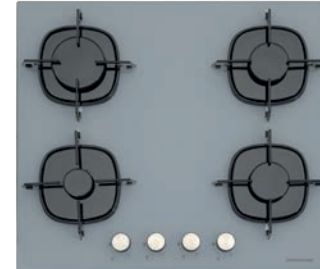
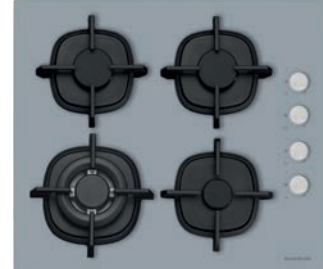
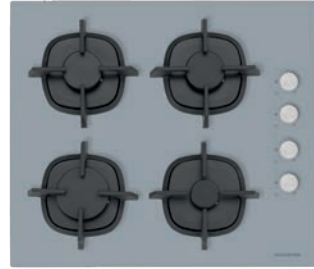

## CS5430S01

<b>Hob Features</b>	Built-in 90cm Black
<b>Comfort Features</b>	Cast Iron Supports 3 Gas Burners 1 Hot Plate Auto Ignition Side Mechanical Control
<b>Safety</b>	Gas Safety Device
<b>Other Features</b>	Product Dimensions (WxDxH): 590 x 520 x 55mm Cut Out Dimensions (WxDxH): 560 x 490mm 1 x Rapid burner: 2900 W 1 x Semi-rapid burner: 1750 W 1 x Auxiliary burner: 1000 W Rear Right Zone Size/Power: 145/1500W Maximum Power: 7150 W Gas Type: NG NG/LPG Options

## CS5343S01

<b>Hob Features</b>	Built-in 60cm Grey
<b>Comfort Features</b>	Cast Iron Pans Supports 4 Gas Burners Auto Ignition Side Mechanical Control
<b>Safety</b>	Gas Safety Device
<b>Other Features</b>	Product Dimensions (WxDxH): 590 x 520 x 55mm Cut Out Dimensions (WxDxH): 560 x 490mm 1 x Rapid burner: 2900 W 2 x Semi-rapid burner: 1750 W 1 x Auxiliary burner: 1000 W Maximum Power: 7400 W Gas Type: NG NG/LPG Options

## CS5429S01

<b>Hob Features</b>	Built-in 60cm Grey
<b>Comfort Features</b>	Cast Iron Pans Supports 3 Gas Burners 1 WOK Auto Ignition Side Mechanical Control
<b>Safety</b>	Gas Safety Device
<b>Other Features</b>	Product Dimensions (WxDxH): 590 x 520 x 55mm Cut Out Dimensions (WxDxH): 560 x 490mm 1 x WOK burner: 3800 W 2 x Semi-rapid burner: 1750 W 1 x Auxiliary burner: 1000 W Maximum Power: 8300 W Gas Type: NG NG/LPG Options

## CS5436S01

<b>Hob Features</b>	Built-in 60cm Grey
<b>Comfort Features</b>	Enamel Pan Supports 4 Gas Burners 1 WOK Auto Ignition Front Mechanical Control
<b>Safety</b>	Gas Safety Device
<b>Other Features</b>	Product Dimensions (WxDxH): 590 x 520 x 55mm Cut Out Dimensions (WxDxH): 560 x 490mm 1 x Rapid burner: 2900 W 2 x Semi-rapid burner: 1750 W 1 x Auxiliary burner: 1000 W Maximum Power: 7400 W Gas Type: NG NG/LPG Options

## CS5349S01

<b>Hob Features</b>	Built-in 60cm Grey
<b>Comfort Features</b>	Enamel Pan Supports 4 Gas Burners Auto Ignition Side Mechanical Control
<b>Safety</b>	Gas Safety Device
<b>Other Features</b>	Product Dimensions (WxDxH): 590 x 520 x 55mm Cut Out Dimensions (WxDxH): 560 x 490mm 1 x Rapid burner: 2900 W 2 x Semi-rapid burner: 1750 W 1 x Auxiliary burner: 1000 W Maximum Power: 7400 W Gas Type: NG NG/LPG Options

## CS5437S01

<b>Hob Features</b>	Built-in 60cm Grey
<b>Comfort Features</b>	Enamel Pan Supports 4 Gas Burners Auto Ignition Front Mechanical Control
<b>Safety</b>	Gas Safety Device
<b>Other Features</b>	Product Dimensions (WxDxH): 590 x 520 x 55mm Cut Out Dimensions (WxDxH): 560 x 490mm 1 x Rapid burner: 2900 W 2 x Semi-rapid burner: 1750 W 1 x Auxiliary burner: 1000 W Maximum Power: 7400 W Gas Type: NG NG/LPG Options

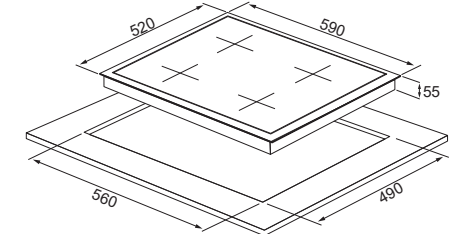
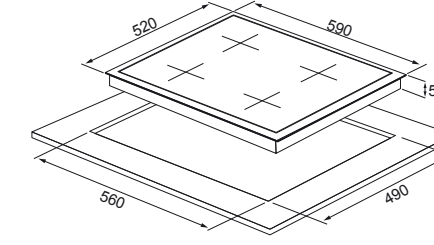
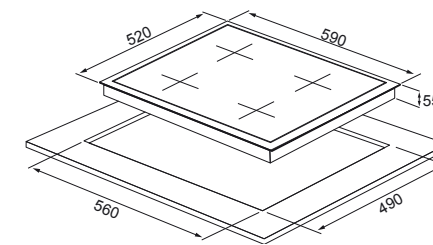
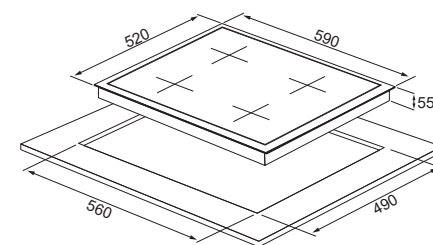
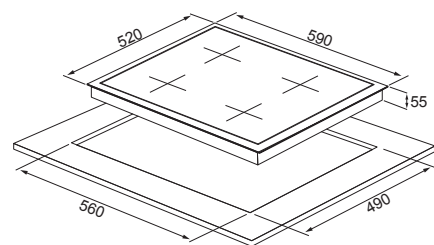
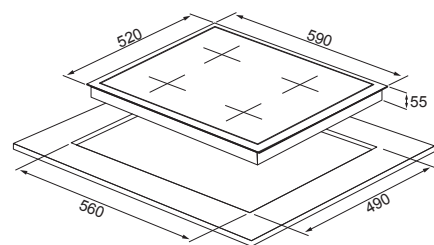



# GLASS BUILT-IN HOBS

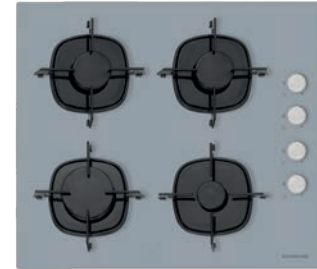

## CS5335S01

<b>Hob Features</b>	Built-in 60cm Grey
<b>Comfort Features</b>	Enamel Pan Supports 4 Gas Burners Auto Ignition Side Mechanical Control
<b>Safety</b>	Gas Safety Device
<b>Other Features</b>	Product Dimensions (WxDxH): 590 x 520 x 55mm Cut Out Dimensions (WxDxH): 560 x 490mm 1 x Rapid burner: 2900 W 2 x Semi-rapid burner: 1750 W 1 x Auxiliary burner: 1000 W Maximum Power: 7400 W Gas Type: NG NG/LPG Options

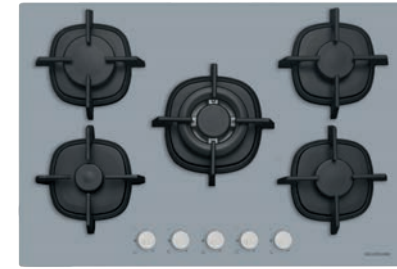
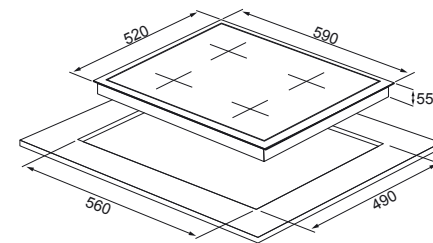

## CS5364S01

<b>Hob Features</b>	Built-in 75cm Grey
<b>Comfort Features</b>	Cast Iron Pans Supports 4 Gas Burners 1 WOK Auto Ignition Front Mechanical Control
<b>Safety</b>	Gas Safety Device
<b>Other Features</b>	Product Dimensions (WxDxH): 750 x 520 x 55mm Cut Out Dimensions (WxDxH): 560 x 490mm 1 x WOK burner: 3800 W 1 x Rapid burner: 2900 W 2 x Semi-rapid burner: 1750 W 1 x Auxiliary burner: 1000 W Maximum Power: 11200 W Gas Type: NG NG/LPG Options

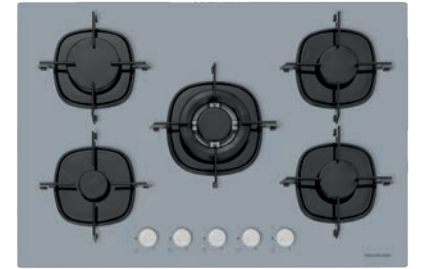
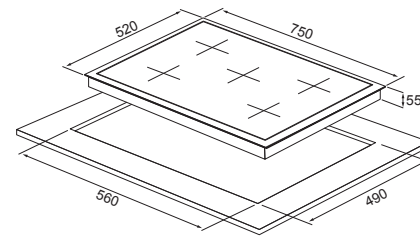

## CS5365S01

<b>Hob Features</b>	Built-in 75cm Grey
<b>Comfort Features</b>	Enamel Pan Supports 4 Gas Burners 1 WOK Auto Ignition Front Mechanical Control
<b>Safety</b>	Gas Safety Device
<b>Other Features</b>	Product Dimensions (WxDxH): 750 x 520 x 55mm Cut Out Dimensions (WxDxH): 560 x 490mm 1 x WOK burner: 3800 W 1 x Rapid burner: 2900 W 2 x Semi-rapid burner: 1750 W 1 x Auxiliary burner: 1000 W Maximum Power: 11200 W Gas Type: NG NG/LPG Options

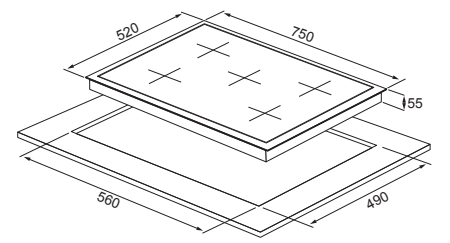

# STAINLESS STEEL HOBS



## AS5631X01

- Hob Features** Built-in  
60cm  
Inox
- Comfort Features** Enamel Pan Supports  
4 Gas Burners  
Auto Ignition  
Side Mechanical Control
- Safety** Gas Safety Device
- Other Features** Product Dimensions (WxDxH):  
590 x 520 x 55mm  
Cut Out Dimensions (WxDxH):  
560 x 490mm  
1 x Rapid burner: 2900 W  
2 x Semi-rapid burner: 1750 W  
1 x Auxiliary burner: 1000 W  
Maximum Power: 1200 W  
Gas Type: NG  
NG/LPG Options

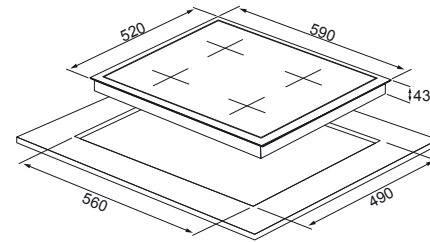

## AS5633X01

- Hob Features** Built-in  
60cm  
Inox
- Comfort Features** Cast Iron Pans Supports  
3 Gas Burners 1 WOK Burner  
Auto Ignition  
Side Mechanical Control
- Safety** Gas Safety Device
- Other Features** Product Dimensions (WxDxH):  
590 x 520 x 55mm  
Cut Out Dimensions (WxDxH):  
560 x 490mm  
1 x WOK burner: 3800 W  
2 x Semi-rapid burner: 1500 W  
1 x Auxiliary burner: 1000 W  
Maximum Power: 7400 W  
Gas Type: NG  
NG/LPG Options

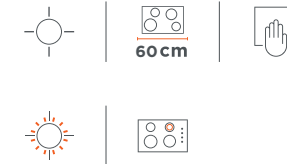
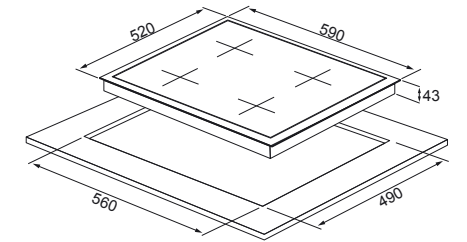

## AS5632X01

- Hob Features** Built-in  
60cm  
Inox
- Comfort Features** Enamel Pan Supports  
3 Gas Burners 1 Electric Burner  
Auto Ignition  
Side Mechanical Control
- Safety** Gas Safety Device
- Other Features** Product Dimensions (WxDxH):  
590 x 520 x 55mm  
Cut Out Dimensions (WxDxH):  
560 x 490mm  
1 x Rapid burner: 2900 W  
1 x Semi-rapid burner: 1750 W  
1 x Electric burner: 1500W  
1 x Auxiliary burner: 1000 W  
Maximum Power: 1500 W  
Gas Type: NG  
NG/LPG Options

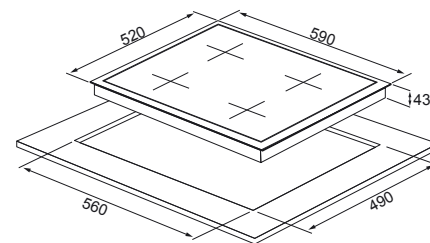

## AS5640X01

- Hob Features** Built-in  
60cm  
Inox
- Comfort Features** Cast Iron Pans Supports  
4 Gas Burners  
Auto Ignition  
Side Mechanical Control
- Safety** Gas Safety Device
- Other Features** Product Dimensions (WxDxH):  
590 x 520 x 55mm  
Cut Out Dimensions (WxDxH):  
560 x 490mm  
1 x Rapid burner: 2900 W  
2 x Semi-rapid burner: 1750 W  
1 x Auxiliary burner: 1000 W  
Maximum Power: 1200 W  
Gas Type: NG  
NG/LPG Options

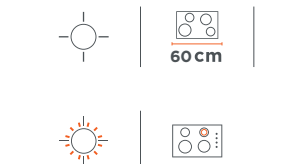
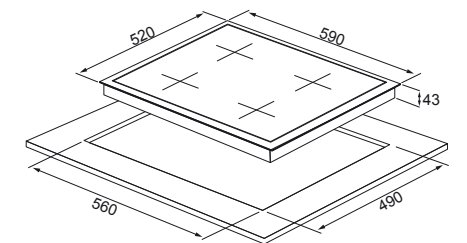

# FREESTANDING HOBS



## FS5425B01

<b>Hob Features</b>	Free Standing 60cm Black
<b>Comfort Features</b>	Enamel Pan Supports 4 Gas Burners Auto Ignition Side Mechanical Control
<b>Safety</b>	Gas Safety Device
<b>Other Features</b>	Product Dimensions (WxDxH): 590 x 520mm 1 x Rapid burner: 2900 W 2 x Semi-rapid burner: 1750 W 1 x Auxiliary burner: 1000 W Maximum Power: 7400 W Gas Type: NG NG/LPG Options



## FS5425S01

<b>Hob Features</b>	Free Standing 60cm Grey
<b>Comfort Features</b>	Enamel Pan Supports 4 Gas Burners Auto Ignition Side Mechanical Control
<b>Safety</b>	Gas Safety Device
<b>Other Features</b>	Product Dimensions (WxDxH): 590 x 520mm 1 x Rapid burner: 2900 W 2 x Semi-rapid burner: 1750 W 1 x Auxiliary burner: 1000 W Maximum Power: 7400 W Gas Type: NG NG/LPG Options



## FS5425W01

<b>Hob Features</b>	Free Standing 60cm White
<b>Comfort Features</b>	Enamel Pan Supports 4 Gas Burners Auto Ignition Side Mechanical Control
<b>Safety</b>	Gas Safety Device
<b>Other Features</b>	Product Dimensions (WxDxH): 590 x 520mm 1 x Rapid burner: 2900 W 2 x Semi-rapid burner: 1750 W 1 x Auxiliary burner: 1000 W Maximum Power: 7400 W Gas Type: NG NG/LPG Options





# REFRIGERATORS

With their advanced functions, Silverline refrigerators keep your food as fresh as the day they were stored.



### **LARGE CAPACITY**

Provides spacious storage area thanks to large inner volume.



### **ELECTRONIC CONTROL**

The "Electronic Control" panel allows the user to set separate temperatures for the fridge and the freezer.



### **VACATION MODE**

This function allows you to operate your refrigerator at low power when you are going to be away from home for a long time. When this function is selected, food in the freezer is kept as they are. To prevent bad odours in the freezer, the temperature is kept at around 12 degrees all the time. Moreover, you also save energy since the compressor does not run continuously in this mode.



### **ANTI-FINGER PRINT**

This feature ensures that the outer surface of the refrigerator looks clean at all times.



### **EXTRA COLD SECTION**

Designed specifically for dairy/breakfast items, the "Chiller Compartment" keeps food between -2°C and +3°C. This compartment is ideal for storing breakfast items and etc..



### **ARTIFICIAL INTELLIGENCE**

Thanks to the "Artificial Intelligence" function, the refrigerator detects the environmental temperature to set its own refrigerator, saving you the trouble of manual setting.



### **MOISTURE CONTROL (VEGETABLE)**

Without the humidity control function, the air inside the crisper evaporates, reaching the food and shortening its life. Thanks to the adjustable "Humidity-Controlled Crisper" function in your refrigerator, the air inside the crisper condenses to allow you to keep humidity ratios of the food under control. This way, food items are kept fresh for a longer time.



### **ICE MAKER**

"Rotary Ice Maker" makes ice in about 2-3 hours. Ice pieces in the container fall into the ice storage container below once the knob on it is turned. The ice storage container is only intended to store ice.



### **NO FROST**

The no-frost system isolates the freezer from humidity, ensuring that the air inside the fridge remains dry. Thus it prevents humidity and frosting on the inner walls of the product to ensure that food does not freeze. Thanks to this system, food items are frozen more quickly, more evenly and balanced matter, remaining as fresh as the first day.



### **BLUE LIGHT**

Equipped with sterilisation function, the "Blue Light" lighting function illuminates fruits and vegetables with a light that has the ideal wavelength, ensuring that they photosynthesise as they do in the nature. Food whose tastes and aromas are preserved remain fresh for a longer time and preserve the vitamin C they contain.



### **TOUCH CONTROL**

Along with a modern appearance, the "Touch Control" offers ease of use in terms of technologic aspects to allow the user to set separate temperatures for each compartment.



### **LED LIGHTING**

It provides a more powerful white light for the interior of the refrigerator.



## HIGH PERFORMANCE REFRIGERATION TECHNOLOGIES

An indispensable element of any kitchen with a unique design and essential functionality. SILVERLINE Refrigerators are equipped with significant technical features such as the Anti-Odor and Air Cleaning System with UV, LED and Platinum Rays, the Anti-bacterial System preventing bacterial growth and propagation, the Vitamin-C Fresh System ensuring moisture control that will allow fruit and vegetables to maintain their nutritional value for longer, and the Multiple Air Flow System that increases the efficiency of your refrigerator. The energy class refrigeration technology offers high performance with minimal operating noise. In addition to providing your kitchen with a contemporary look thanks to their elegant aesthetic and inox steel finish, they also maintain a clean appearance cleanliness thanks to their fingerprint-resistant surface. The changeable opening direction of the doors provides for flexible installation that can be adapted kitchens of all styles.

## REFRIGERATORS

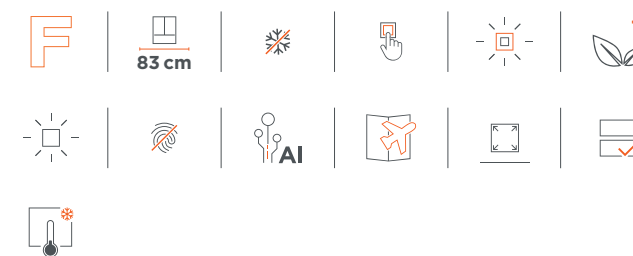

### R12051B04

<b>General Feature</b>	Cross Door Refrigerator Blue LED Light Sterilization Function Artificial Intelligence Function Black Colour Glass Door 492lt Total Gross Volume 482lt Total Net Volume
<b>Cooling System</b>	F Energy Class Touch Control Panel T Climate Type Multi Air Flow Total No Frost
<b>Fridge Compartment</b>	3 glass shelves on fridge part 6 shelves on fridge door balcony 2 crisper drawers Egg rack
<b>Freezer Compartment</b>	4 Stars Freezer 6 Drawers Freezer
<b>Dimension</b>	Product Dimension (WDH): 833x654x1820mm Loading Quantity 40'HQ: 52 pcs

### R12051W04

<b>General Feature</b>	Cross Door Refrigerator Blue LED Light Sterilization Function Artificial Intelligence Function White Colour Glass Door 492lt Total Gross Volume 482lt Total Net Volume
<b>Cooling System</b>	F Energy Class Touch Control Panel T Climate Type Multi Air Flow Total No Frost
<b>Fridge Compartment</b>	3 glass shelves on fridge part 6 shelves on fridge door balcony 2 crisper drawers Egg rack
<b>Freezer Compartment</b>	4 Stars Freezer 6 Drawers Freezer
<b>Dimension</b>	Product Dimension (WDH): 833x654x1820mm Loading Quantity 40'HQ: 52 pcs

# REFRIGERATORS

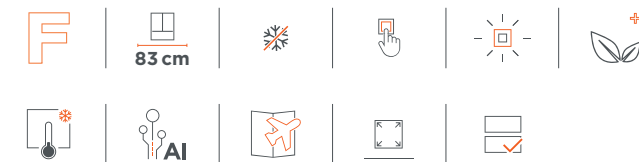
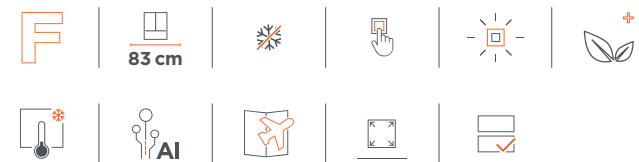

## R12051F04

<b>General Feature</b>	Cross Door Refrigerator Blue LED Light Sterilization Function Artificial Intelligence Function Mirror Colour Glass Door 492lt Total Gross Volume 482lt Total Net Volume
<b>Cooling System</b>	F Energy Class Touch Control Panel T Climate Type Multi Air Flow Total No Frost
<b>Fridge Compartment</b>	3 glass shelves on fridge part 6 shelves on fridge door balcony 2 crisper drawers Egg rack
<b>Freezer Compartment</b>	4 Stars Freezer 6 Drawers Freezer
<b>Dimension</b>	Product Dimension (WDH): 833x654x1820mm Loading Quantity 40'HQ: 52 pcs

## R12051X04

<b>General Feature</b>	Cross Door Refrigerator Blue LED Light Sterilization Function Artificial Intelligence Function Inox Door 492lt Total Gross Volume 482lt Total Net Volume
<b>Cooling System</b>	F Energy Class Touch Control Panel T Climate Type Multi Air Flow Total No Frost
<b>Fridge Compartment</b>	3 glass shelves on fridge part 6 shelves on fridge door balcony 2 crisper drawers Egg rack
<b>Freezer Compartment</b>	4 Stars Freezer 6 Drawers Freezer
<b>Dimension</b>	Product Dimension (WDH): 833x654x1820mm Loading Quantity 40'HQ: 52 pcs

## R12046B01

<b>General Feature</b>	Side By Side Refrigerator Holiday Function Door Opened Over Alarm Black Colour Glass Door 562lt Total Gross Volume 514 Lt Net Capacity
<b>Cooling System</b>	F Energy Class Led Touch Screen ST Climate Multi Air Flow Total No Frost
<b>Fridge Compartment</b>	Quick Cooling Function 4 shelves on fridge door balcony 2 crisper drawers Egg rack
<b>Freezer Compartment</b>	Quick Freezing Function 4 shelves on freezer door balcony
<b>Dimension</b>	Product Dimension: W910 x D650(+Handle 700) x H1770 Loading Quantity 40'HQ: 48 pcs

## R12066X01

<b>General Feature</b>	Side By Side Refrigerator 25L variable compartment volume Inox Door 520lt Total Gross Volume 474L Net Total Volume
<b>Cooling System</b>	F Energy Class Electronic LED Display Control T climate type Multi Air Flow Total No Frost
<b>Fridge Compartment</b>	Egg rack
<b>Freezer Compartment</b>	4stars freezer 12kg freezer capacity
<b>Dimension</b>	Unit Dimension: 920*630*1765mm Loading Capatiy 40HQ: 52pcs

# REFRIGERATORS

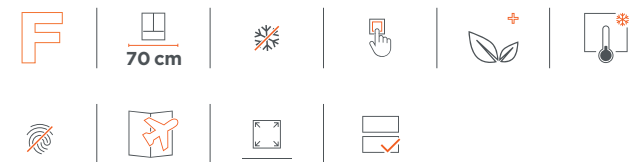

## R12073X01

<b>General Feature</b>	Combi Type Refrigerator Recessed Handle Revisable Door Inox Door 416l Total Net Volume 468l Total Gross Volume
<b>Cooling System</b>	F Energy Class Electronic Touch Control Panel T Climate Type Total No Frost Multi Air Flow
<b>Fridge Compartment</b>	3 shelves on fridge door balcony 2 crisper drawers Egg rack
<b>Freezer Compartment</b>	4stars freezer 3 Drawers Freezer
<b>Dimension</b>	Unit Dimension (WDH): 700x666x1880 Loading Capaty 40HQ: 67pcs

## R12074X01

<b>General Feature</b>	Combi Type Refrigerator Recessed Handle Revisable Door Inox Door 295l Total Net Volume 325l Total Gross Volume
<b>Cooling System</b>	F Energy Class Electronic Touch Control Panel T Climate Type Total No Frost Multi Air Flow
<b>Fridge Compartment</b>	5 shelves on fridge door balcony 2 crisper drawers Egg rack
<b>Freezer Compartment</b>	4stars freezer 3 Drawers Freezer
<b>Dimension</b>	Unit Dimension (WDH): 595x630x1880 Loading Capaty 40HQ: 72pcs

## R12074B01

<b>General Feature</b>	Combi Type Refrigerator Recessed Handle Revisable Door Black Colour Glass Door 295l Total Net Volume 325l Total Gross Volume
<b>Cooling System</b>	F Energy Class Electronic Touch Control Panel T Climate Type Total No Frost Multi Air Flow
<b>Fridge Compartment</b>	5 shelves on fridge door balcony 2 crisper drawers Egg rack
<b>Freezer Compartment</b>	4 stars freezer 3 Drawers Freezer
<b>Dimension</b>	Unit Dimension (WDH): 595x630x1880 Loading Capaty 40HQ: 72pcs

## R12074W01

<b>General Feature</b>	Combi Type Refrigerator Recessed Handle Revisable Door White Color Glass Door 295l Total Net Volume 325l Total Gross Volume
<b>Cooling System</b>	F Energy Class Electronic Touch Control Panel T Climate Type Total No Frost Multi Air Flow
<b>Fridge Compartment</b>	5 shelves on fridge door balcony 2 crisper drawers Egg rack
<b>Freezer Compartment</b>	4 stars freezer 3 Drawers Freezer
<b>Dimension</b>	Unit Dimension (WDH): 595x630x1880 Loading Capaty 40HQ: 72pcs



# REFRIGERATORS



## R12060W01

<b>General Feature</b>	Combi Type Refrigerator Grip handle optional Reversible door White Colour 260l Total Net Volume 267l Total Gross Volume
<b>Cooling System</b>	F Energy Class Safety glass ST Climate Type Static ECO LED light
<b>Fridge Compartment</b>	2L bottle rack Fruit and vegetable crisper Egg rack
<b>Freezer Compartment</b>	3 Drawers Freezer
<b>Dimension</b>	Dimension(WxDxH): 545x585x1800(without handle) Load Capacity 40HQ: 100pcs



## R12064X01

<b>General Feature</b>	Double Door TMF Refrigerator Recessed handle Reversible door Inox Door 425l Total net volume 459l Total gross volume
<b>Cooling System</b>	F Energy Class Electronic control T Climate Type Total no frost Led Light
<b>Fridge Compartment</b>	2 shelves Chiller Drawer Fruit and vegetable crisper Egg rack
<b>Freezer Compartment</b>	2 Balcony Freezer 4 star rating freezer
<b>Dimension</b>	Product Size (WxDxH): 700x670x1770 mm Load Capacity 40HQ: 66pcs



## R12044X01

<b>General Feature</b>	Double Door TMF Refrigerator Recessed handle Reversible door Inox Door 294l Total net volume 304l Total gross volume
<b>Cooling System</b>	A+ Energy Class Mechanical control T Climate Type Total No Frost Led Light
<b>Fridge Compartment</b>	3 shelves 3 Balcony Fridge Fruit and vegetable crisper Egg rack
<b>Freezer Compartment</b>	1 shelf on freezer 4 star rating freezer
<b>Dimension</b>	Product Size (WxDxH): 595*695*1724 mm Load Capacity 40HQ: 72pcs



## R12047S01

<b>General Feature</b>	Double Door TMF Refrigerator Recessed handle Reversible door Silver Colour Door 311l Total net volume 319l Total gross volume
<b>Cooling System</b>	F Energy Class Mechanical Control ST Climate Tpe Static Led Light
<b>Fridge Compartment</b>	3 shelves 3 Balcony Fridge Fruit and vegetable crisper Egg rack
<b>Freezer Compartment</b>	1 shelf on freezer 4 star rating freezer
<b>Dimension</b>	Dimension Product (WxDxH) : 60x60x170 cm Load Capacity 40HQ: 73pcs

# REFRIGERATORS



## R12069W03

<b>General Feature</b>	Built-in Combi Refrigerator Reversible door White Colour Cabinet 241l Total net volume 250l Total gross volume
<b>Cooling System</b>	F Energy Class Electronic control T Climate Tpe Total No Frost Interior light
<b>Fridge Compartment</b>	Recessed Space for Beverage 2L bottle rack Fruit and vegetable crisper Egg rack
<b>Freezer Compartment</b>	Sliding Box for Pizza 2 Drawers Freezer
<b>Dimension</b>	Product dimension (WxDxH): 540x545x1772 Load Capacity (40HQ) : 105

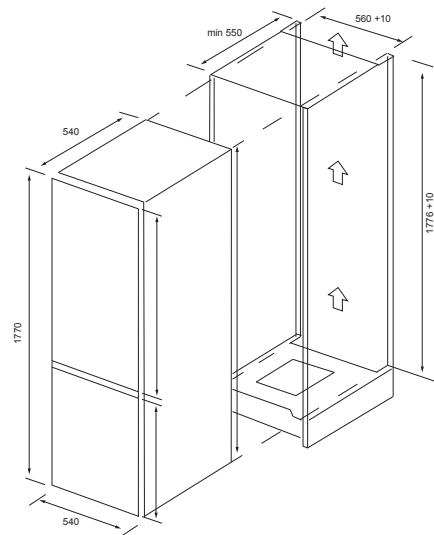

# REFRIGERATORS



## R12058W04

<b>General Feature</b>	Built-in Combi Refrigerator Reversible door White Colour Cabinet 250l Total net volume 259l Total gross volume
<b>Cooling System</b>	F Energy Class Electronic control ST Climate Tpe Static Interior light
<b>Fridge Compartment</b>	3 shelves 2L bottle rack Fruit and vegetable crisper Egg rack
<b>Freezer Compartment</b>	4 star rating freezer 3 Drawers Freezer
<b>Dimension</b>	Product Size (WxDxH): 540x540x1785 mm Load Capacity (40HQ) : 109

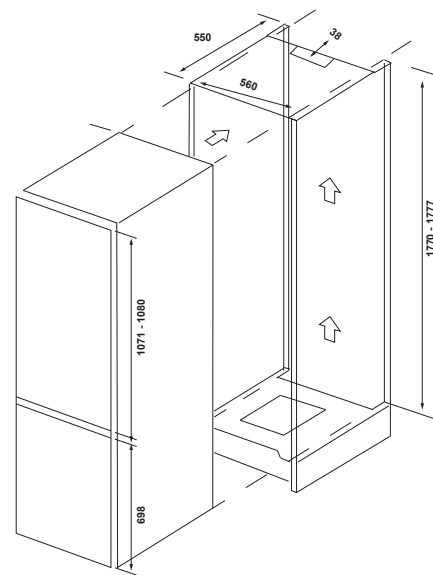

## R12056W01

<b>General Feature</b>	Double Door TMF Refrigerator Recessed handle Reversible door White Colour Door 240l Total net volume 245l Total gross volume
<b>Cooling System</b>	F Energy Class Mechanical control ST Climate Tpe Static Interior light
<b>Fridge Compartment</b>	3 shelves 2L bottle rack Fruit and vegetable crisper Egg rack
<b>Freezer Compartment</b>	1 shelf on freezer 4 star rating freezer
<b>Dimension</b>	Dimension(WxDxH)(mm): 550x550x 1590 Load Capacity (40HQ) : 108



## R12042W01

<b>General Feature</b>	Mini Fridge Reversible door Adjustable leg White Colour Door 93l Total net volume 108l Total gross volume
<b>Cooling System</b>	F Energy Class Mechanical control T Climate Tpe Static
<b>Fridge Compartment</b>	Tempered glass shelf 2L bottle rack Fruit and vegetable crisper Egg rack
<b>Freezer Compartment</b>	Separate freezer compartment
<b>Dimension</b>	Dimension(WxDxH)(mm): 472x450x850 Load Capacity (40HQ) : 338pcs

## REFRIGERATORS



### R12075W01

<b>General Feature</b>	Minibar Recessed handle Reversible door White Colour Door 43l Total net volume 45l Total gross volume
<b>Cooling System</b>	F Energy Class Mechanical control T Climate Tpe Static
<b>Fridge Compartment</b>	1 wire shelf
<b>Freezer Compartment</b>	Separate freezer compartment
<b>Dimension</b>	Unit Dimenison 472x450x492 Load Capacity (40HQ) : 573pcs



### R12093W01

<b>General Feature</b>	Minibar Recessed handle Reversible door White Colour Door 43l Total net volume 45l Total gross volume
<b>Cooling System</b>	F Energy Class Mechanical control ST Climate Tpe Static
<b>Fridge Compartment</b>	Crisper Drawer Egg Rack
<b>Freezer Compartment</b>	4 Star Rating Freezer
<b>Dimension</b>	Unit Dimenison 818x595x545 Load Capacity (40HQ) : 230pcs

## FREEZERS



### F22005S02

<b>General Feature</b>	Chest Freezer Silver Colour 99lt Total Net Volume Lock Grip Handle LED Light
<b>Cooling System</b>	A+ Energy Class Mechanical Control T Climate Type Static
<b>Dimension</b>	Product Dimension (WDH): 565x523x850mm Loading Quantity 40'HQ: 248 pcs



### F22009S02

<b>General Feature</b>	Chest Freezer Silver Colour 142lt Total Net Volume Lock Grip Handle LED Light
<b>Cooling System</b>	A+ Energy Class Mechanical Control T Climate Type Static
<b>Dimension</b>	Product Dimension (WDH): 5730x523x850mm Loading Quantity 40'HQ: 248 pcs

# FREEZERS



A<sup>+</sup>

## F22015S01

<b>General Feature</b>	Chest Freezer Silver Colour 198lt Total Net Volume Lock Grip Handle LED Light
<b>Cooling System</b>	A+ Energy Class Mechanical Control T Climate Type Static
<b>Dimension</b>	Product Dimension (WDH): 9450x523x850mm Loading Quantity 40'HQ: 214 pcs

F |

## F22006W01

<b>General Feature</b>	Upright Freezer White Colour 85lt Total Net Volume 92lt Total Net Volume Recessed Handle Transparent drawers
<b>Cooling System</b>	F Energy Class Electronic Control T Climate Type Static
<b>Dimension</b>	Product Dimension (WDH): 550x580x850mm Loading Quantity 40'HQ: 236 pcs

F |

## F22012X01

<b>General Feature</b>	Upright Freezer Inox Door 163 l Total Net Volume 182 l Total gross Volume 6 drawers Transparent drawers
<b>Cooling System</b>	F Energy Class Electronic Control T Climate Type Static
<b>Dimension</b>	Product Dimension (WDH): 550x580x1420mm Loading Quantity 40'HQ: 142 pcs

F |

## F22007X01

<b>General Feature</b>	Upright Freezer Inox Door Net Volume: 225 L Gross Volume: 245L 7 drawers Transparent drawers
<b>Cooling System</b>	F Energy Class Electronic Control T Climate Type Static
<b>Dimension</b>	Product Dimension (WDH): 600x600x1700mm Loading Quantity 40'HQ: 74 pcs



# DISHWASHERS

A genuinely functional space that makes life easier after a pleasant meal, complete with an aesthetic look and functionality that helps make your kitchen more ergonomic.

# DISHWASHERS



**E** | **11** Settings | **5** Program

## D11035X01

**Main Features** Full-Integrated Dishwasher  
Capacity for 11 place settings  
Energy consumption: E  
9 LT Water Consumption  
49dB noise level  
Button control with screen  
3/6/9 hours  
Half Load  
Black Control Panel

**Program** Intensive  
Eco  
Light  
Rapid  
Pre-Rinse

**Controls** Buttons

**Technical & Internal Specification** SS Filter  
3 Grey baskets  
Upper & lower spray arms  
Water softener  
Flip Dispenser detergent box  
Aqua-stop inlet hose

**E** | **12** Settings | **6** Program

## D11011X01

**Main Features** Full-Integrated Dishwasher  
Capacity for 12 place settings  
Energy consumption: E  
11 LT Water Consumption  
49dB noise level  
Button control  
3/6/9 hours delay start  
Half Load  
White body + Black Control Panel + Silver buttons

**Program** Intensive  
Normal  
Eco  
Glass  
1 hour  
Rapid

**Controls** Buttons

**Technical & Internal Specification** SS Filter  
2 Grey baskets  
Upper & lower spray arms  
Water softener  
Sliding Dispenser detergent box  
Aqua-stop inlet hose

**E** | **14** Settings | **6** Program

## D11024X01

**Main Features** Full-Integrated Dishwasher  
Capacity for 14 place settings  
Energy consumption: E  
11 LT Water Consumption  
52dB noise level  
Button control with screen  
1-24 hr delay start  
Half Load  
White body + Black Control Panel + Silver buttons

**Program** 90min  
Glass  
Rapid  
Normal  
Intensive  
Eco

**Controls** Buttons

**Technical & Internal Specification** SS Filter  
3 Grey baskets  
Upper & lower spray arms  
Water softener  
Flip Dispenser detergent box  
Aqua stop inlet hose

**E** | **12** Settings | **5** Program

## D11033B01

**Main Features** Full-Integrated Dishwasher  
Capacity for 12 place settings  
Energy consumption: E  
12 LT Water Consumption  
49dB noise level  
Button control with screen  
1-24 hr delay start  
Black Glass Door

**Program** Eco  
Rapid  
Intensive  
Rapid  
Pre-Rinse  
Light

**Controls** Buttons

**Technical & Internal Specification** SS Filter  
2 Grey baskets  
Upper & lower spray arms  
Water softener  
Flip Dispenser detergent box  
Aqua stop inlet hose

**E** | **12** Settings | **6** Program

## D11030B01

**Main Features** Semi-Integrated Dishwasher  
Capacity for 12 place settings  
Energy consumption: E  
11 LT Water Consumption  
49dB noise level  
Button control  
1-24 hr delay start  
Black colour panel

**Program** 1H  
Pre-Rinse  
Eco  
Light  
Rapid  
Intensive

**Controls** Buttons

**Technical & Internal Specification** SS Filter  
2 Grey baskets  
Upper & lower spray arms  
Water softener  
Flip Dispenser detergent box  
Aqua stop inlet hose

**E** | **12** Settings | **5** Program

## D11033W01

**Main Features** Full-Integrated Dishwasher  
Capacity for 12 place settings  
Energy consumption: E  
12 LT Water Consumption  
49dB noise level  
Button control with screen  
1-24 hr delay start  
White Glass Door

**Program** Eco  
Rapid  
Intensive  
Rapid  
Pre-Rinse  
Light

**Controls** Buttons

**Technical & Internal Specification** SS Filter  
2 Grey baskets  
Upper & lower spray arms  
Water softener  
Flip Dispenser detergent box  
Aqua stop inlet hose

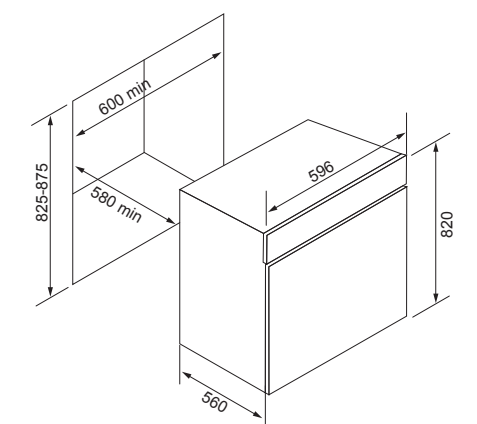
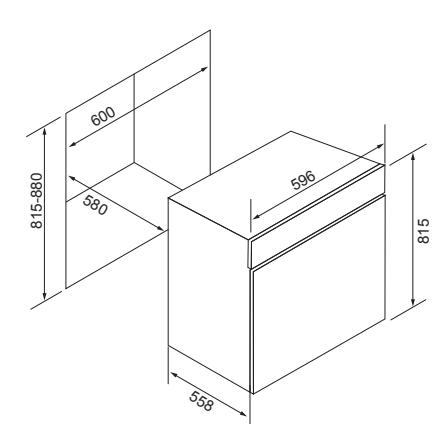
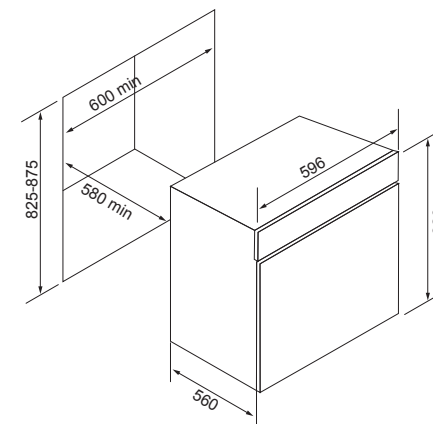
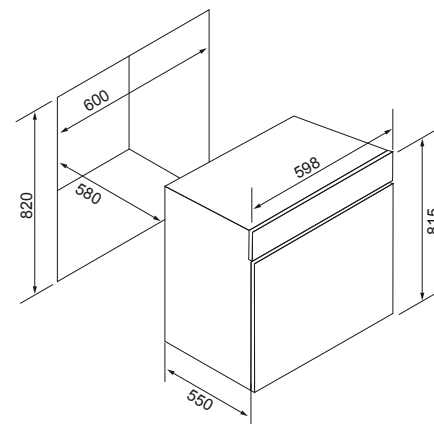
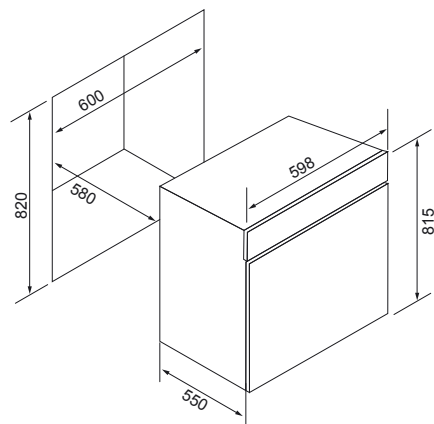
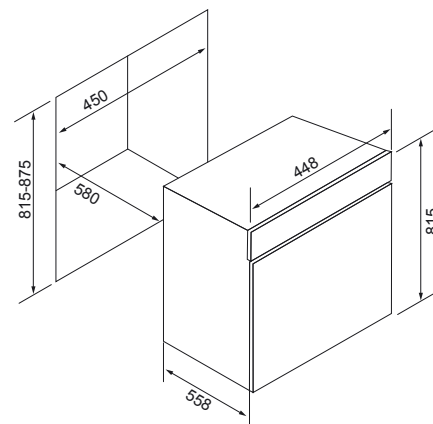

# DISHWASHERS



**E** | **12** Settings | **6** Program

## D11030S01

<b>Main Features</b>	Semi-Integrated Dishwasher Capacity for 12 place settings Energy consumption: E 11 LT Water Consumption 49dB noise level Button control 1-24 hr delay start Silver colour panel
<b>Program</b>	1H Pre-Rinse Eco Light Rapid Intensive
<b>Controls</b>	Buttons
<b>Technical &amp; Internal Specification</b>	SS Filter 2 Grey baskets Upper & lower spray arms Water softener Flip Dispenser detergent box Aqua stop inlet hose



**E** | **14** Settings | **8** Program

## D11026X01

<b>Main Features</b>	Freestanding Dishwasher Capacity for 14 place settings Energy consumption: E 10 LT Water Consumption 52dB noise level Button control Inox Door
<b>Program</b>	90min Pre-Rinse Eco Light Glass Rapid Normal Intensive
<b>Controls</b>	Buttons
<b>Technical &amp; Internal Specification</b>	SS Filter 3 Grey baskets Upper & lower & middle spray arms Water softener Sliding Dispenser detergent box



**E** | **12** Settings | **7** Program

## D11038X01

<b>Main Features</b>	Freestanding Dishwasher Capacity for 12 place settings Energy consumption: E 11 LT Water Consumption 49dB noise level Button control with screen 1-24 hr delay start Half Load Inox Door
<b>Program</b>	Intensive Eco Glass 90min Rapid Self Cleaning Pre-rinse
<b>Controls</b>	Buttons
<b>Technical &amp; Internal Specification</b>	Plastic base & SS Filter 3 Grey baskets Upper & lower & middle spray arms Water softener Flip Dispenser detergent box

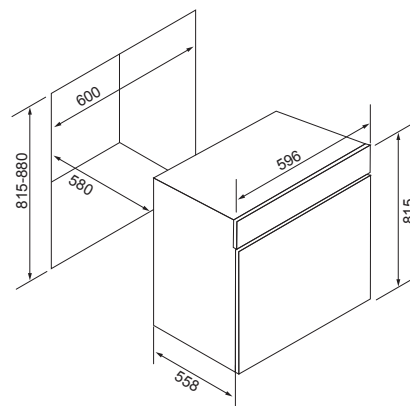





## WASHING MACHINES

Silverline washing machines are designed to meet a multitude of requirements while fitting perfectly into any home and space.

# WASHING MACHINES



**E** | **9** Kg | **15** Program

## WM14024S02

<b>Features</b>	Freestanding Washing Machine Silver Color Washing Capacity : 9 kg Button & Knob Control with big screen Door Lock Auto Balance System Anti-Foam Control Overheating Control Child lock Galvanized Door Frame
<b>Performance</b>	E Energy Class 1400 RPM 57,6l Water consumption (L/Cycle) Universal motor
<b>Programs</b>	Daily 80' Daily 183' Cool Wash 95C Anti-Bac Denim Heavy Drum Clean Spin Rinse+Spin Night Wash Quick Mix Silk Wool Synthetic
<b>Dimension</b>	Loading Quantity (40HQ) 215 Dimension (W*D*H) 595x545x845mm

**E** | **6** Kg | **8** Program

## WM14016S01

<b>Features</b>	Freestanding Washing Machine Silver Color Washing Capacity : 6 kg Button & Knob Control Drum 41L Child-Lock Pre Delay/Time Delay
<b>Performance</b>	E Energy Class 1000 RPM 48l Water consumption (L/Cycle) Universal motor
<b>Programs</b>	Rinse + spin Cotton Mix Synthetic Delicate Tub Clean Spin Quick 15'
<b>Dimension</b>	Loading Quantit (40HQ) 225 Dimension (W*D*H) 595x480x850mm

**A<sup>++</sup>** | **7** Kg | **12** Program

## WM14017S01

<b>Features</b>	Freestanding Washing Machine Silver Color Washing Capacity : 7 kg Button & Knob Control with small screen Drum 58L Child-Lock Pre Delay/Time Delay
<b>Performance</b>	A+++ Energy Class 1200 RPM 52,5l Water consumption (L/Cycle) Universal motor
<b>Programs</b>	Cotton Sports Mix Eco Baby Care Quick 15' Rinse + spin Spin Underwear Duvet Synthetic Wool
<b>Dimension</b>	Loading Quantity (40HQ) 215 Dimension (W*D*H) 595x510x850mm

**B** | **8** Kg | **5** Kg | **16** Program

## WM14035W01

<b>Features</b>	Freestanding Washing Machine White Color Washing Capacity : 8 kg Dryer Capacity : 5 kg Button & Knob Control with big screen Auto Balance System Anti-Foam Control Overheating Control Child lock
<b>Performance</b>	B Energy Class 1400 RPM 56l Water consumption (L/Cycle) Intensive motor
<b>Programs</b>	Intensive Quick Spin Rinse+Spin Mix Cotton Synthetics Wool Down Jacket Allergy Care Underwear Jeans Dryer Super Dryer Deodorize Anti-Mite
<b>Dimension</b>	Loading Quantity (40HQ) 171 Dimension (W*D*H) 595x560x850mm

**A<sup>++</sup>** | **8,5** Kg | **16** Program

## WM14015B01

<b>Features</b>	Freestanding Washing Machine Black Color Washing Capacity : 8,5 kg Button & Knob Control with big screen Child-Lock Pre Delay/Time Delay
<b>Performance</b>	A+++ Energy Class 1200 RPM 51l Water consumption (L/Cycle) Inverter motor
<b>Programs</b>	Dark Color Shirt Intensive Bedding Quick Drum Clean Spin Mix Cotton Synthetic Down Jacket Allergy Care Underwear Wool Jeans
<b>Dimension</b>	Loading Quantity (40HQ) 171 Dimension (W*D*H) 595x560x850mm

**B** | **8** Kg | **15** Program

## DM54003S01

<b>Features</b>	Freestanding Condenser Dryer Silver Color Drying Capacity : 8 kg Galvanized Door Frame Round Door Moisture sensing Button & Knob Control with big screen Power-off memorization Two large filter Anti-crease function Delay timer: 1-24hr
<b>Performance</b>	B Energy Class Automatic Tumble Dryer
<b>Programs</b>	Daily Cotton Synthetic Bulky Item Towel Wool Duve Baby Care Warm Air Refresh Time Underwear Jeans Shirts Sportswear
<b>Dimension</b>	Loading Quantity (40HQ) 162 Dimension (W*D*H) 595x630x890 mm



silverline.com

SILVERLINE BUILT-IN APPLIANCES CO.  
Silkar Plaza. Topkapı-Maltepe St. No: 6 Floor: 3  
Bayrampaşa / İstanbul / TURKEY P.O. 34030  
Phone: +90212.484 48 00 (pbx) Fax: +90212.481 40 08

[contact@silverline.com](mailto:contact@silverline.com)

 / [SilverlineWorld](#)  / [WorldSilverline](#)  / [SilverlineAnkastre](#)